

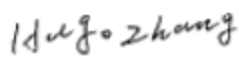



TEST REPORT IEC 62109-1 Safety of Power Converter for use in Photovoltaic Power Systems Part 1: General requirements	
Report Number. :	GZES190601959601
Date of issue..... :	08/07/2019
Total number of pages..... :	70
Name of Testing Laboratory preparing the Report..... :	SGS-CSTC Standards Technical Services Co., Ltd. Guangzhou Branch
Applicant's name..... :	EVOLVE ENERGY GROUP CO., LIMITED
Address..... :	RM 702, 7/F FU FAI COMM CTR 27 HILLIER ST SHEUNG WAN, HK
Test specification:	
Standard..... :	IEC/EN 62109-1:2010 (First Edition)
Test procedure..... :	Characteristic Examination
Non-standard test method..... :	N/A
Test Report Form No..... :	IEC62109_1B
Test Report Form(s) Originator.... :	VDE Testing and Certification Institute
Master TRF..... :	Dated 2016-04
<p>Copyright © 2016 IEC System of Conformity Assessment Schemes for Electrotechnical Equipment and Components (IECEE System). All rights reserved.</p> <p>This publication may be reproduced in whole or in part for non-commercial purposes as long as the IECEE is acknowledged as copyright owner and source of the material. IECEE takes no responsibility for and will not assume liability for damages resulting from the reader's interpretation of the reproduced material due to its placement and context.</p> <p>If this Test Report Form is used by non-IECEE members, the IECEE/IEC logo and the reference to the CB Scheme procedure shall be removed.</p> <p>This report is not valid as a CB Test Report unless signed by an approved CB Testing Laboratory and appended to a CB Test Certificate issued by an NCB in accordance with IECEE 02.</p>	
General disclaimer:	
<p>The test results presented in this report relate only to the object tested.</p> <p>This report shall not be reproduced, except in full, without the written approval of the Issuing CB Testing Laboratory. The authenticity of this Test Report and its contents can be verified by contacting the NCB, responsible for this Test Report.</p>	



Test item description	Three phase Solar Grid-tied Inverter
Trade Mark	
Manufacturer	EVOLVE ENERGY GROUP CO., LIMITED
Model/Type reference	EVVO 60000TL3P
Ratings	DC input: 250-1000V, Max. 40/40/40A AC output: 3~/N/PE 230/400Vac, 50Hz, 90A, 60000VA Serial Number: ZJ1ES160HCJ252 Firmware version: V2.00

Responsible Testing Laboratory (as applicable), testing procedure and testing location(s):		
<input type="checkbox"/>	CB Testing Laboratory:	
Testing location/ address.....:		
<input type="checkbox"/>	Associated CB Testing Laboratory:	
Testing location/ address.....:		
Tested by (name, function, signature).....:		
Approved by (name, function, signature)....:		
<input checked="" type="checkbox"/>	Testing procedure: CTF Stage 1:	SGS-CSTC Standards Technical Services Co., Ltd. Guangzhou Branch
Testing location/ address.....:		198 Kezhu Road, Science City, Economic & Technology Development Area, Guangzhou, Guangdong, China
Tested by (name, function, signature).....:		Hugo Zhang (Project Engineer) 
Approved by (name, function, signature)....:		Roger Hu (Technical Reviewer) 
<input type="checkbox"/>	Testing procedure: CTF Stage 2:	
Testing location/ address.....:		
Tested by (name + signature).....:		
Witnessed by (name, function, signature)....:		
Approved by (name, function, signature)....:		
<input type="checkbox"/>	Testing procedure: CTF Stage 3:	
<input type="checkbox"/>	Testing procedure: CTF Stage 4:	
Testing location/ address.....:		
Tested by (name, function, signature).....:		
Witnessed by (name, function, signature)....:		
Approved by (name, function, signature)....:		
Supervised by (name, function, signature) ..:		

List of Attachments (including a total number of pages in each attachment):		
50 Hz		
Attachment #	Description	Pages
Attachment I	Pictures of the EUT and Electrical Schemes	17 pages
Attachment II	Testing Information	2 pages

Summary of testing:	
<p>Tests performed (name of test and test clause):</p> <p>The equipment has been tested according to the standard: IEC 62109-1:2010. Testing has been carried out at 50 Hz</p> <p>All applicable tests according to the above specified standard have been carried out.</p> <p>From the result of inspection and tests on the submitted sample, we conclude that it complies with the requirements of the standard.</p> <p>Remarks: All the test results are from the report below:</p> <ul style="list-style-type: none"> - IEC/EN 62109-1:2010 (First Edition): <p>Test Report No: GZES180400449801</p>	<p>Testing location:</p> <p>Shenzhen SOFAR SOLAR Co., Ltd. 5/F, Building 4, Antongda Industrial Park, No. 1 Liuxian Avenue, Xin'an Street, Bao'an District, Shenzhen City, Guangdong Province, P.R. China</p>

Summary of compliance with National Differences (List of countries addressed):
No National Differences are addressed to this test report

Copy of marking plate:

EVVO Solar Grid-tied Inverter	
Model No:	EVVO 60000TL3P
Max.DC Input Voltage	1000V
Operating MPPT Voltage Range	250~950V
Max. Input Current	40A/40A/40A
Max. PV Isc	48A/48A/48A
Nominal Grid Voltage	3/N/PE,400Vac
Max.Output Current	90A
Nominal Grid Frequency	50/60Hz
Nominal Output Power	60000W
Max.Output Power	60000VA
Power Factor	>0.99(adjustable+/-0.8)
Ingress Protection	IP65
Operating Temperature Range	-25°C~+60°C
Protective Class	Class I
Factory - Shenzhen China	
Manufacturer : EVOLVE ENERGY GROUP CO., LIMITED	
Address :RM 702, 7/F FU FAI COMM CTR 27 HILLIER ST SHEUNG WAN, HK	
Global Head Quarters	
371 Sidco Industrial Estate	
Chennai 600098 India	
VDE0126-1-1,VDE-AR-N4105,G99,IEC61727, IEC62116,AS4777	
	

Note:

1. The above markings are the minimum requirements required by the safety standard. For the final production samples, the additional markings which do not give rise to misunderstanding may be added.
2. Label is attached on the side surface of enclosure and visible after installation
3. Labels of other models are as the same with EVVO 60000TL3P's except the parameters of rating.

Test item particulars	Three Phase Inverter			
Equipment mobility	<input type="checkbox"/> movable	<input type="checkbox"/> hand-held	<input type="checkbox"/> stationary	
	<input checked="" type="checkbox"/> fixed	<input type="checkbox"/> transportable	<input type="checkbox"/> for building-in	
Connection to the mains	<input type="checkbox"/> pluggable equipment	<input type="checkbox"/> direct plug-in		
	<input checked="" type="checkbox"/> permanent connection	<input type="checkbox"/> for building-in		
Environmental category	<input checked="" type="checkbox"/> outdoor	<input type="checkbox"/> indoor unconditional	<input type="checkbox"/> indoor conditional	
Over voltage category Mains	<input type="checkbox"/> OVC I	<input type="checkbox"/> OVC II	<input checked="" type="checkbox"/> OVC III	<input type="checkbox"/> OVC IV
Over voltage category PV	<input type="checkbox"/> OVC I	<input checked="" type="checkbox"/> OVC II	<input type="checkbox"/> OVC III	<input type="checkbox"/> OVC IV
Mains supply tolerance (%)	-90 / +110 %			
Tested for power systems	TN systems			
IT testing, phase-phase voltage (V)	N/A			
Class of equipment	<input checked="" type="checkbox"/> Class I	<input type="checkbox"/> Class II	<input type="checkbox"/> Class III	
	<input type="checkbox"/> Not classified			
Mass of equipment (kg)	Appro. 70kg			
Pollution degree	Outside PD3; Inside PD2			
IP protection class	IP 65			
Possible test case verdicts:				
- test case does not apply to the test object	N/A			
- test object does meet the requirement	P (Pass)			
- test object was not evaluated for the requirement	N/E			
- test object does not meet the requirement	F (Fail)			
Testing	CTF Stage 1 procedure			
Date of receipt of test item	N/A			
Date (s) of performance of tests	10 th Oct 2018 to 21 th Nov 2018			

General remarks:

"(See Enclosure #)" refers to additional information appended to the report.
 "(See appended table)" refers to a table appended to the report.

This document is issued by the Company subject to its General Conditions of Service printed overleaf, available on request or accessible at www.sgs.com/terms_and_conditions.htm and, for electronic format documents, subject to Terms and Conditions for Electronic Documents at www.sgs.com/terms_e-document.htm. Attention is drawn to the limitation of liability, indemnification and jurisdiction issues defined therein. Any holder of this document is advised that information contained hereon reflects the Company's findings at the time of its intervention only and within the limits of Client's instructions, if any. The Company's sole responsibility is to its Client and this document does not exonerate parties to a transaction from exercising all their rights and obligations under the transaction documents. This document cannot be reproduced except in full, without prior written approval of the Company. Any unauthorized alteration, forgery or falsification of the content or appearance of this document is unlawful and offenders may be prosecuted to the fullest extent of the law. Unless otherwise stated the results shown in this test report refer only to the sample(s) tested.

Throughout this report a comma / point is used as the decimal separator.

Manufacturer's Declaration per sub-clause 4.2.5 of IEC62109 02:

The application for obtaining a CB Test Certificate includes more than one factory location and a declaration from the Manufacturer stating that the sample(s) submitted for evaluation is (are) representative of the products from each factory has been provided..... :

- Yes
- Not applicable

When differences exist; they shall be identified in the General product information section.

Name and address of factory (ies) : **Shenzhen SOFAR SOLAR Co., Ltd.**
 5/F, Building 4, Antongda Industrial Park, No. 1
 Liuxian Avenue, Xin'an Street, Bao'an District,
 Shenzhen City, Guangdong Province, P.R. China

General product information:

Product covered by this report is grid-connected PV inverter for indoor or outdoor installation. The connection to the DC input and AC output are through connectors.

The Solar inverter converts DC voltage into AC voltage.

The input and output are protected by varistors to Earth. The unit is providing EMC filtering at the output toward mains. The unit does not provide galvanic separation from input to output (transformerless). The output is switched off redundant by the high power switching bridge and a two relays. This assures that the opening of the output circuit can operate in case of single fault.

Equipment under testing:

-EVVO 60000TL3P

The variants models are:

-EVVO 50000TL3P

-EVVO 70000TL3P-HV

Model Number	EVVO 50000TL3P	EVVO 60000TL3P	EVVO 70000TL3P-HV
Full load MPP DC voltage range	530-800Vd.c.		660-800Vd.c.
Max. input voltage	250-1000Vd.c.		
Max. input current	40Ad.c./30Ad.c./ 30Ad.c.	40Ad.c./40Ad.c./ 40Ad.c.	
Rated grid voltage	3P/N/PE 230/400Vac		3P/PE 480Vac
Rated grid frequency	50Hz		
Rated output power	50KW	60KW	70KW
Rated output current	80Aa.c Max.	90Aa.c Max.	
Power factor	0.8 leading..0.8 lagging		

The variants models have been included in this test report without tests because the following features don't change regarding to the tested model:

- Same connection system and hardware topology
- Same control algorithm.
- Output power within 2,5 and 2/3 of the EUT or Modular inverters
- Same Firmware Version

IEC 62109-1			
Clause	Requirement – Test	Result – Remark	Verdict
4	GENERAL TESTING REQUIREMENTS		
4.1	General		P
4.2	General conditions for testing		P
4.2.1	Sequence of tests		P
4.2.2	Reference test conditions		P
4.2.2.1	Environmental conditions	Max. 60°C rated ambient temperature tested.	P
4.2.2.2	State of equipment		P
4.2.2.3	Position of equipment	Be fixed in accordance with the manufacturer's instruction	P
4.2.2.4	Accessories		N/A
4.2.2.5	Covers and removable parts		N/A
4.2.2.6	Mains supply a) Voltage: b) Frequency: c) Polarity: d) Earthing: e) Over-current Protection:	(see appended table 4.2.2.6)	P
4.2.2.7	Supply ports other than the mains		P
4.2.2.7.1	Photovoltaic supply sources a) Open circuit voltage: b) Short-circuit current:	(see appended table 4.2.2.7)	P
4.2.2.7.2	Battery inputs	No battery input	N/A
4.2.2.8	Conditions of loading for output ports		P
4.2.2.9	Earthing terminals		P
4.2.2.10	Controls		N/A
4.2.2.11	Available short circuit current		P
4.3	Thermal testing	(see appended table 4.3)	P
4.3.1	General		P
4.3.2	Maximum temperatures		P
4.3.2.1	General		P
4.3.2.2	Touch temperatures		P
4.3.2.3	Temperature limits for mounting surfaces		P
4.4	Testing in single fault condition	(see appended table 4.4)	P
4.4.1	General		P
4.4.2	Test conditions and duration for testing under fault conditions		P
4.4.2.1	General		P

4.4.2.2	Duration of tests		P
4.4.3	Pass/fail criteria for testing under fault conditions		P
4.4.3.1	Protection against shock hazard		P
4.4.3.2	Protection against the spread of fire		P
4.4.3.3	Protection against other hazards		P
4.4.3.4	Protection against parts expulsion hazards		P
4.4.4	Single fault conditions to be applied		P
4.4.4.1	Component fault tests		P
4.4.4.2	Equipment or parts for short-term or intermittent operation		P
4.4.4.3	Motors	No motors	N/A
4.4.4.4	Transformer short circuit tests		P
4.4.4.5	Output short circuit		P
4.4.4.6	Backfeed current test for equipment with more than one source of supply		P
4.4.4.7	Output overload		P
4.4.4.8	Cooling system failure		P
4.4.4.9	Heating devices		N/A
4.4.4.10	Safety interlock systems		N/A
4.4.4.11	Reverse d.c. connections		P
4.4.4.12	Voltage selector mismatch	No voltage selector	N/A
4.4.4.13	Mis-wiring with incorrect phase sequence or polarity		P
4.4.4.14	Printed wiring board short-circuit test	No insulation distance less than the required spacing.	N/A
4.5	Humidity preconditioning	(see appended table 7.5)	P
4.5.1	General		P
4.5.2	Conditions	95% R.H. 40°C. 48H	P
4.6	Backfeed voltage protection		P
4.6.1	Backfeed tests under normal conditions		P
4.6.2	Backfeed tests under single-fault conditions	PV input is separated from grid with basic insulation under normal and single-fault conditions with disconnection method evaluated to EN 62109-2	P
4.6.3	Compliance with backfeed tests		P
4.7	Electrical ratings tests	(see appended table 4.2.2.6)	P
4.7.1	Input ratings		P
4.7.1.1	Measurement requirements for DC input ports		P
4.7.2	Output ratings		P

5	MARKING AND DOCUMENTATION		P
5.1	Marking		--
5.1.1	General		P
	Equipment shall bear markings as specified in 5.1 and 5.2	Label are marked on PCE and graphic symbol is explained in user manual	P
	Graphic symbols may be used and shall be in accordance with Annex C or IEC 60417 as applicable.		P
	Graphic symbols shall be explained in the documentation provided with the PCE.		P
5.1.2	Durability of markings		P
	Markings required by this clause to be located on the PCE shall remain clear and legible under conditions of NORMAL USE and resist the effects of cleaning agents specified by the manufacturer		P
5.1.3	Identification		P
	The equipment shall, as a minimum, be permanently marked with:		P
	a) the name or trade mark of the manufacturer or supplier	Trade mark: 	P
	b) model number, name or other means to identify the equipment	EVVO 50000TL3P EVVO 60000TL3P EVVO 70000TL3P-HV	P
	c) a serial number, code or other marking allowing identification of manufacturing location and the manufacturing batch or date within a three month time period.	Within three month	P
5.1.4	Equipment ratings	See below	P
	Unless otherwise specified in another part of IEC 62109, the following ratings, as applicable shall be marked on the equipment:	Special requirement as IEC/EN 62109-2	P
	– input voltage, type of voltage (a.c. or d.c.), frequency, and max. continuous current for each input	Refer to the marking label on page 5	P
	– output voltage, type of voltage (a.c. or d.c.), frequency, max. continuous current, and for a.c. outputs, either the power or power factor for each output	Refer to the marking label on page 5	P
	– the ingress protection (IP) rating as in 6.3 below	IP 65	P
5.1.5	Fuse identification	The fuse is secure on the PCB. It cannot access by operator.	P
	Marking shall be located adjacent to each fuse or fuseholder, or on the fuseholder, or in another location provided that it is obvious to which fuse the marking applies, giving the fuse current rating and where fuses of different voltage rating value could be fitted, the fuse voltage rating.		P

	Where fuses with special fusing characteristics such as time delay or breaking capacity are necessary, the type shall also be indicated		N/A
	For fuses not located in operator access areas and for soldered-in fuses located in operator access areas, it is permitted to provide an unambiguous cross-reference (for example, F1, F2, etc.) to the servicing instructions which shall contain the relevant information.		P
5.1.6	Terminals, Connections, and Controls		P
	If necessary for safety, an indication shall be given of the purpose of Terminals, connectors, controls, and indicators, and their various positions, including any connections for coolant fluids such as water and drainage. The symbols in Annex C may be used, and where there is insufficient space, symbol 9 of Annex C may be used.	“+” and “-” marked close to DC input connect. “L” “N” and “GND” marked close to AC output terminal block.	P
	Push-buttons and actuators of emergency stop devices, and indicator lamps used only to indicate a warning of danger or the need for urgent action shall be coloured red.	No such device.	N/A
	A multiple-voltage unit shall be marked to indicate the particular voltage for which it is set when shipped from the factory. The marking is allowed to be in the form of a paper tag or any other non-permanent material.	The PCE is not intended to connect to multiple-voltage and there is no voltage setting device.	N/A
	A unit with d.c. terminals shall be plainly marked indicating the polarity of the connections, with:	See below	P
	– the sign “+” for positive and “-” for negative; or		P
	– a pictorial representation illustrating the proper polarity where the correct polarity can be unambiguously determined from the representation	Not provided	N/A
5.1.6.1	Protective Conductor Terminals		P
	The means of connection for the protective earthing conductor shall be marked with:	The protective earthing terminal is connected via AC connector.	P
	– symbol 7 of Annex C; or		P
	– the letters “PE”; or		N/A
	– the colour coding green-yellow.		N/A
5.1.7	Switches and circuit-breakers		N/A
	The on and off-positions of switches and circuits breakers shall be clearly marked. If a push-button switch is used as the power switch, symbols 10 and 16 of Annex C may be used to indicate the on-position, or symbols 11 and 17 to indicate the off-position, with the pair of symbols (10 and 16, or 11 and 17) close together.		N/A
5.1.8	Class II Equipment	Class I	N/A
	Equipment using Class II protective means throughout shall be marked with symbol 12 of		N/A

	Annex C. Equipment which is only partially protected by DOUBLE INSULATION or REINFORCED INSULATION shall not bear symbol 12 of Table Annex C.		
	Where such equipment has provision for the connection of an earthing conductor for functional reasons (see 7.3.6.4) it shall be marked with symbol 6 of Annex C		N/A
5.1.9	Terminal boxes for External Connections	No such terminal box	N/A
	Where required by note 1 of Table 2 as a result of high temperatures of terminals or parts in the wiring compartment, there shall be a marking, visible beside the terminal before connection, of either:		N/A
	a) the minimum temperature Rating and size of the cable to be connected to the TERMINALS; or		N/A
	b) a marking to warn the installer to consult the installation instruction. Symbol 9 of Table D-1 is an acceptable marking		N/A
5.2	Warning markings		P
5.2.1	Visibility and legibility requirements for warning markings		P
	Warning markings shall be legible, and shall have minimum dimensions as follows:		P
	– Printed symbols shall be at least 2,75 mm high		P
	– Printed text characters shall be at least 1.5 mm high and shall contrast in colour with the background		P
	– Symbols or text that are moulded, stamped or engraved in a material shall have a character height of at least 2,0 mm, and if not contrasting in colour from the background, shall have a depth or raised height of at least 0,5 mm.		P
	If it is necessary to refer to the instruction manual to preserve the protection afforded by the equipment, the equipment shall be marked with symbol 9 of Annex C	The manual provide necessary information for warning marking	P
	Symbol 9 of Annex C is not required to be used adjacent to symbols that are explained in the manual		P
5.2.2	Content for warning markings		P
5.2.2.1	Ungrounded heat sinks and similar parts	Grounded heatsink and metal enclosure	N/A
	An ungrounded heat sink or other part that may be mistaken for a grounded part and involves a risk of electric shock in accordance with 7.3 shall be marked with symbol 13 of Annex C, or equivalent. The marking may be on or adjacent to the heat sink and shall be clearly visible when the PCE is disassembled to the extent that a risk of contact with the heat sink exists.		N/A
5.2.2.2	Hot Surfaces		P

	A part of the PCE that exceeds the temperature limits specified in 4.3.2 shall be marked with symbol 14 of Annex C or equivalent.		P
5.2.2.3	Coolant	Coolant is not used	N/A
	A unit containing coolant that exceeds 70 °C shall be legibly marked externally where readily visible after installation with symbol 15 of Annex C. The documentation shall provide a warning regarding the risk of burns from hot coolant, and either:		N/A
	a) statement that coolant system servicing is to be done only by SERVICE PERSONNEL, or		N/A
	b) instructions for safe venting, draining, or otherwise working on the cooling system, if these operations can be performed without OPERATOR access to HAZARDS internal to the equipment		N/A
5.2.2.4	Stored energy		P
	Where required by 7.3.9.2 or 7.4.2 the PCE shall be marked with Symbol 21 of Annex C and the time to discharge capacitors to safe voltage and energy levels shall accompany the symbol.		P
5.2.2.5	Motor guarding		N/A
	Where required by 8.2 a marking shall be provided where it is visible to service personnel before removal of a guard, warning of the hazard and giving instructions for safe servicing (for example disconnection of the source before removing the guard).	No motor inside enclosure	N/A
5.2.3	Sonic hazard markings and instructions	Hazardous noise level not produced	N/A
	If required by 10.2.1 a PCE shall:		N/A
	a) be marked to warn the operator of the sonic pressure hazard; or		N/A
	b) be provided with installation instructions that specify how the installer can ensure that the sound pressure level from equipment at its point of use after installation, will not reach a value, which could cause a hazard. These instructions shall include the measured sound pressure level, and shall identify readily available and practicable protective materials or measures which may be used.		N/A
5.2.4	Equipment with multiple sources of supply		P
	A PCE with connections for multiple energy sources shall be marked with symbol 13 of Annex C and the manual shall contain the information required in 5.3.4.		P
	The symbol shall be located on the outside of the unit or shall be prominently visible behind any cover giving access to hazardous parts.		P
5.2.5	Excessive touch current		N/A
	Where required by 7.3.6.3.7 the PCE shall be	The touch current does not	N/A

	marked with symbol 15 of Annex C. See also 5.3.2 for information to be provided in the installation manual.	exceed limited	
5.3	Documentation		P
5.3.1	General		P
	The documentation provided with the PCE shall provide the information needed for the safe operation, installation, and (where applicable) maintenance of the equipment. The documentation shall include the items required in 5.3.2 through 5.3.4, and the following:		P
	a) explanations of equipment makings, including symbols used		P
	b) location and function of terminals and controls		P
	c) all ratings or specifications that are necessary to safely install and operate the PCE, including the following environmental ratings along with an explanation of their meaning and any resulting installation requirements:		P
	– ENVIRONMENTAL CATEGORY as per 6.1	Outdoor	P
	– WET LOCATIONS classification for the intended external environment as per 6.1	Suitable for wet location	P
	– POLLUTION DEGREE classification for the intended external environment as per 6.2	PD 3 outside. PD2 inside	P
	– INGRESS PROTECTION rating as per 6.3	IP 65	P
	– Ambient temperature and relative humidity ratings	Max. +60°C and 100% R.H.	P
	– MAXIMUM altitude rating	2000m	P
	– OVERVOLTAGE CATEGORY assigned to each input and output port as per 7.3.7.1.2, accompanied by guidance regarding how to ensure that the installation complies with the required overvoltage categories;	OVC II(PV), OVC III(Mains)	P
	d) a warning that when the photovoltaic array is exposed to light, it supplies a d.c. voltage to the PCE		P
5.3.1.1	Language	English provide	P
	Instructions related to safety shall be in a language that is acceptable in the country where the equipment is to be installed.	For other country language further evaluated is needed	N/A
5.3.1.2	Format		P
	In general, the documentation must be provided in printed form and is to be delivered with the equipment.	Printed form provided	P
	For equipment which requires the use of a computer for both installation and operation, documentation may be provided in electronic format without accompanying printed format.		N/A
5.3.2	Information related to installation		P

	The documentation shall include installation and where applicable, specific commissioning instructions and, if necessary for safety, warnings against hazards which could arise during installation or commissioning of the equipment. The information provided shall include:		P
	a) assembly, location, and mounting requirements;		P
	b) ratings and means of connection to each source of supply and any requirements related to wiring and external controls, colour coding of leads, disconnection means, or overcurrent protection needed, including instructions that the installation position shall not prevent access to the disconnection means;		P
	c) ratings and means of connection of any outputs from the PCE, and any requirements related to wiring and external controls, colour coding of leads, or overcurrent protection needed;		P
	d) explanation of the pin-out of connectors for external connections, unless the connector is used for a standard purpose (e.g. RS 232)		P
	e) ventilation requirements;		P
	f) requirements for special services, for example cooling liquid;	No special services	N/A
	g) instructions and information relating to sound pressure level if required by 10.2.1;		N/A
	h) where required by 14.8.1.3, instructions for the adequate ventilation of the room or location in which PCE containing vented or valve-regulated batteries is located, to prevent the accumulation of hazardous gases;	No such battery	N/A
	i) tightening torque to be applied to wiring terminals;		N/A
	j) values of backfeed short-circuit currents available from the PCE on input and output conductors under fault conditions, if those currents exceed the max. rated current of the circuit, as per 4.4.4.6;	Not exceeds the max. rated current.	N/A
	k) for each input to the PCE, the max value of short-circuit current available from the source, for which the PCE is designed; and		P
	l) compatibility with RCD and RCM;	Internal RCM is used	N/A
	m) instructions for protective earthing, including the information required by 7.3.6.3.7 if a second protective earthing conductor is to be installed:	Touch current is not exceed limit	N/A
	n) where required by 7.3.8, the installation instructions shall include the following or equivalent wording:		N/A
	“This product can cause a d.c. current in the external protective earthing conductor. Where a residual current-operated protective (RCD) or	Internal RCM is used	N/A

	monitoring (RCM) device is used for protection in a case of direct or indirect contact, only an RCD or RCM of Type B is allowed on the supply side of this product.”		
	o) for PCE intended to charge batteries, the battery nominal voltage rating, size, and type	Grid interactive	N/A
	p) PV array configuration information, such as ratings, whether the array is to be grounded or floating, any external protection devices needed, etc.		N/A
5.3.3	Information related to operation		P
	Instructions for use shall include any operating instructions necessary to ensure safe operation, including the following, as applicable:		P
	– Instructions for adjustment of controls including the effects of adjustment;		P
	– Instructions for interconnection to accessories and other equipment, including indication of suitable accessories, detachable parts and any special materials;		P
	– Warnings regarding the risk of burns from surfaces permitted to exceed the temperature limits of 4.3.2 and required operator actions to reduce the risk; and		P
	– Instructions, that if the equipment is used in a manner not specified by the manufacturer, the protection provided by the equipment may be impaired.		P
5.3.4	Information related to maintenance		P
	Maintenance instructions shall include the following:		P
	– Intervals and instructions for any preventive maintenance that is required to maintain safety (for example air filter replacement or periodic re-tightening of terminals);		P
	– Instructions for accessing operator access areas, if any are present, including a warning not to enter other areas of the equipment;		N/A
	– Part numbers and instructions for obtaining any required operator replaceable parts;	No such part	N/A
	– Instructions for safe cleaning (if recommended)		N/A
	– Where there is more than one source of supply energizing the PCE, information shall be provided in the manual to indicate which disconnect device or devices are required to be operated in order to completely isolate the equipment.		P
5.3.4.1	Battery maintenance	No battery inside	N/A
	Where required by 14.8.5, the documentation shall include the applicable items from the following list of instructions regarding maintenance of batteries:		N/A

	– Servicing of batteries should be performed or supervised by personnel knowledgeable about batteries and the required precautions		N/A
	– When replacing batteries, replace with the same type and number of batteries or battery packs		N/A
	– General instructions regarding removal and installation of batteries		N/A
	– CAUTION: Do not dispose of batteries in a fire. The batteries may explode.		N/A
	– CAUTION: Do not open or damage batteries. Released electrolyte is harmful to the skin and eyes. It may be toxic.		N/A
	– CAUTION: A battery can present a risk of electrical shock and high short-circuit current. The following precautions should be observed when working on batteries:		N/A
	a) Remove watches, rings, or other metal objects.		N/A
	b) Use tools with insulated handles.		N/A
	c) Wear rubber gloves and boots.		N/A
	d) Do not lay tools or metal parts on top of batteries		N/A
	e) Disconnect charging source prior to connecting or disconnecting battery terminals		N/A
	f) Determine if battery is inadvertently grounded. If inadvertently grounded, remove source from ground. Contact with any part of a grounded battery can result in electrical shock. The likelihood of such shock can be reduced if such grounds are removed during installation and maintenance (applicable to equipment and remote battery supplies not having a grounded supply circuit).		N/A
6	ENVIRONMENTAL REQUIREMENTS AND CONDITIONS		P
	The manufacturer shall rate the PCE for the following environmental conditions:		P
	– ENVIRONMENTAL CATEGORY, as in 6.1 below	Outdoor use	P
	– Suitability for WET LOCATIONS or not	Yes	P
	– POLLUTION DEGREE rating in 6.2 below	PD3 outside. PD2 inside	P
	– INGRESS PROTECTION (IP) rating, as in 6.3 below	IP 65	P
	– Ultraviolet (UV) exposure rating, as in 6.4 below	Yes	P
	– Ambient temperature and relative humidity ratings, as in 6.5 below	Max. 60°C, 100%R.H.	P
6.1	Environmental categories and minimum environmental conditions		P
6.1.1	Outdoor		P
6.1.2	Indoor, unconditioned		N/A

6.1.3	Indoor, conditioned		N/A
6.2	Pollution degree	PD3 outside. PD2 inside	P
6.3	Ingress Protection	IP 65	P
6.4	UV exposure	Yes	P
6.5	Temperature and humidity	Max. 60°C, 100%R.H.	P
7	PROTECTION AGAINST ELECTRIC SHOCK AND ENERGY HAZARDS		P
7.1	General		P
7.2	Fault conditions	Normal and single fault condition are considered	P
7.3	Protection against electric shock		P
7.3.1	General	In the PCE the earthed metal enclosure is evaluated by means of basic insulation from DVC C circuit DVC A circuit and unearthed accessible parts are evaluated by means of reinforced insulation from DVC C or protective impedance DVC C circuit: The PV input and the Main output DVC A circuit: The signal communication output port.	P
7.3.2	Decisive voltage classification		P
7.3.2.1	Use of decisive voltage class (DVC)	Working voltage and protective measure and considered	P
7.3.2.2	Limits of DVC (according table 6)	Wet location is considered for PCE outside only	P
7.3.2.3	Short-terms limits of accessible voltages under fault conditions		P
7.3.2.4	Requirements for protection (according table 7)	Single fault condition is considered	P
7.3.2.5	Connection to PELV and SELV circuits	The external signal communication port is considered as SELV	P
7.3.2.6	Working voltage and DVC		P
7.3.2.6.1	General	Transients and voltage fluctuation are disregarded. And worst case normal operation condition is considered	P
7.3.2.6.2	AC working voltage (see Figure 2)		P
7.3.2.6.3	DC working voltage (see Figure 3)		P
7.3.2.6.4	Pulsating working voltage (see Figure 4)		P
7.3.3	protective separation	In the PCE the earthed metal enclosure is evaluated by means of basic insulation from DVC C circuit DVC A circuit and unearthed accessible parts are evaluated	P

		by means of reinforced insulation from DVC C or protective impedance DVC C circuit: The PV input and the Main output DVC A circuit: The signal communication output port	
	Protective separation shall be achieved by:		P
	<ul style="list-style-type: none"> ▪ double or reinforced insulation, or 		P
	<ul style="list-style-type: none"> ▪ protective screening, i.e. by a conductive screen connected to earth by protective bonding in the PCE, or connected to the protective earth conductor itself, whereby the screen is separated from live parts by at least basic insulation, or 		P
	<ul style="list-style-type: none"> ▪ protective impedance comprising limitation of current per 7.3.5.3 and of discharged energy per 7.3.5.4, or 		P
	<ul style="list-style-type: none"> ▪ limitation of voltage according to 7.3.5.4. 		N/A
	The protective separation shall be fully and effectively maintained under all conditions of intended use of the PCE		P
7.3.4	Protection against direct contact		P
7.3.4.1	General		P
	Protection against direct contact is employed to prevent persons from touching live parts that do not meet the requirements of 7.3.5 and shall be provided by one or more of the measure given in 7.3.4.2 (enclosures and barriers) and 7.3.4.3 (insulation).	Enclosure provided	P
	Open type sub-assemblies and devices do not require protective measures against direct contact but the instruction provided with the equipment must indicate that such measures must be provided in the end equipment or in the installation.	End use product	N/A
	Product intended for installation in CLOSED ELECTRICAL OPERATING AREAS, (see 3.9) need not have protective measures against direct contact, except as required by 7.3.4.2.4.	Not use under this condition	N/A
7.3.4.2	Protection by means of enclosures and barriers		P
	The following requirements apply where protection against contact with live parts is provided by enclosures or barriers, not by insulation in accordance with 7.3.4.3.	Enclosure provided to prevent access to inside live parts	P
7.3.4.2.1	General		P
	Parts of enclosures and barriers that provide protection in accordance with these requirements shall not be removable without the use of a tool (see 7.3.4.2.3).	Secured by screws	P
	Polymeric materials used to meet these requirements shall also meet the requirements of 13.6	The plastic board as part of enclosure is evaluated as clause 13.6	P

7.3.4.2.2	Access probe criteria		P
	Protection is considered to be achieved when the separation between the test probes and live parts, when tested as described below, is as follows:		P
	a) decisive voltage classification A, (DVC A) - the probe may touch the live parts	The signal is considered as DVC A	P
	b) decisive voltage classification B, (DVC B) - the probe must not touch bare live parts	The DVC B circuit is not accessible by probe	P
	c) decisive voltage classification C, (DVC C) – the probe must have adequate clearance to live parts, based on the clearance for Basic insulation using the recurring peak working voltage involved,	The DVC C circuit is not accessible by probe	P
7.3.4.2.3	Access probe tests		P
	Compliance with 7.3.4.2.1 is checked by all of the following:		P
	a) Inspection; and		P
	b) Tests with the test finger (Figure D.1) and test pin (Figure D.2) of 0E, the results of which shall comply with the requirements of 7.3.4.2.1 a), b), and c) as applicable. Probe tests are performed on openings in the enclosures after removal of parts that can be detached or opened by an operator without the use of a tool, including fuseholders, and with operator access doors and covers open. It is permitted to leave lamps in place for this test. Connectors that can be separated by an operator without use of a tool, shall also be tested during and after disconnection. Any movable parts are to be put in the most unfavourable position.		P
	The test finger and the test pin are applied as above, without appreciable force, in every possible position, except that floor-standing equipment having a mass exceeding 40 kg is not tilted.		P
	Equipment intended for building-in or rack mounting, or for incorporation in larger equipment, is tested with access to the equipment limited according to the method of mounting detailed in the installation instructions.		N/A
	c) Openings preventing the entry of the jointed test finger (Figure E-1 of 0E) during test b) above, are further tested by means of straight unjointed test finger (Figure E-3 of 0E), applied with a force of 30 N. If the unjointed finger enters, the test with the jointed finger is repeated except that the finger is applied using any necessary force up to 30 N.		N/A
	d) In addition to a) – c) above, top surfaces of enclosure shall be tested with the IP3X probe of IEC 60529. The test probe shall not penetrate the top surface of the enclosure when probed		N/A

	from the vertical direction $\pm 5^\circ$ only.		
7.3.4.2.4	Service access areas	Inside PCE are not intentionally touched with energized part when installation and maintenance. Symbol 21 of Annex C are marked on PCE and explained in user manual	P
7.3.4.3	Protection by means of insulation of live parts	The earthed enclosure is with basic insulation from the live parts inside	P
	Where the requirements of 7.3.4.2 are not met, live parts shall be provided with insulation if:		P
	– their working voltage is greater than the maximum limit of decisive voltage class A, or		P
	– for a DVC A or B circuit, protective separation from adjacent circuit of DVC C is not provided (see note “†” under Table 7)		P
7.3.5	Protection in case of direct contact	The single communication port are direct contact and evaluated with reinforced insulation from live part	P
7.3.5.1	General		P
	Protection in case of direct contact is required to ensure that contact with live parts does not produce a shock hazard.		P
	The protection against direct contact according to 7.3.4 is not required if the circuit contacted is separated from other circuits according to 7.3.2.3, and:	Considered	P
	– is of decisive voltage class A and complies with 7.3.5.2, or	The single communication port is DVC A and reinforced insulation from the live part by means of isolation transformer and optocoupler	P
	– is provided with protective impedance according to 7.3.5.3, or		N/A
	– is limited in voltage according to 7.3.5.4		N/A
	In addition to the measures as given in 7.3.5.2 to 7.3.5.4, it shall be ensured that in the event of error or polarity reversal of connectors no voltages that exceed DVC A can be connected into a circuit with protective separation. This applies for example to plug-in-sub-assemblies or other plug-in devices which can be plugged-in without the use of a tool (key) or which are accessible without the use of a tool.	Considered	P
	Conformity is checked by visual inspection and trial insertion.		P
7.3.5.2	Protection using decisive voltage class A	The single communication port is DVC A and reinforced insulation from the live part by means of isolation transformer and optocoupler	P

7.3.5.3	Protection by means of protective impedance	Protective impedance not used as protective separation in the PCE	N/A
	Circuits and conductive parts do not require protection against direct contact if any connection to circuits of DVC-B or DVC-C is through protective impedance, and the accessible circuit or part is otherwise provided with protective separation from circuits of DVC-B or DVC-C according 7.3.3.		N/A
7.3.5.3.1	Limitation of current through protective impedance		N/A
	The current available through protective impedance to earth and between simultaneously accessible parts, measured at the accessible live parts, shall not exceed a value of 3,5 mA a.c. or 10 mA d.c. under normal and single-fault conditions.		N/A
7.3.5.3.2	Limitation of discharging energy through protective impedance		N/A
	The discharging energy available between simultaneously accessible parts protected by protective impedance shall not exceed the charging voltage and capacitance limits given in Table 9, which applies to both wet and dry locations, under normal and single fault conditions. Refer to figure 8.		N/A
7.3.5.4	Protection by means of limited voltages	No such design	N/A
	That portion of a circuit that has its voltage reduced to DVC-A by a voltage divider that complies with the following requirements, and that is otherwise provided with protective separation from circuits of DVC-B or DVC-C according to 7.3.3, does not require protection against direct contact.		N/A
	The voltage divider shall be designed so that under normal and single fault conditions, including faults in the voltage division circuit, the voltage across the output of the voltage divider does not exceed the limit for DVC-A.		N/A
	This type of protection shall not be used in case of protective class II or unearthed circuits, because it relies on protective earth being connected.		N/A
7.3.6	Protection against indirect contact		P
7.3.6.1	General		P
	Protection against indirect contact is required to prevent shock- hazardous current being accessible from conductive parts during an insulation failure. This protection shall comply with the requirements for protective class I (basic insulation plus protective earthing), class II (double or reinforced insulation) or class III (limitation of voltages)	Class I also with reinforced insulation design inside PCE	P
	That part of a PCE meets the requirements of 7.3.6.2 and 7.3.6.3 is defined as protective class I	The earthed metal enclosure meets this requirement	P
	That part of a PCE meets the requirements of 7.3.6.4 is defined as protective class II.	The signal communication port is reinforced insulation from live parts inside	N/A
	That part of PCE which meets the requirements of		N/A

	decisive voltage class A and in which no hazardous voltages are derived, is defined as protective class III. No shock hazard is present in such circuits.		
	Where protection against indirect contact is dependent on means provided during installation, the installation instructions shall provide details of the required means and shall indicate the associated hazards.	The manual requires the PCE must be securely earthed	P
7.3.6.2	Insulation between live parts and accessible conductive parts		P
	Accessible conductive parts of equipment shall be separated from live parts by insulation meeting the requirements of Table 7 or by clearances as specified in 7.3.7.4 and creepages as specified in 7.3.7.5	See Cl. 7.3.7.4 and Cl. 7.3.7.5	P
7.3.6.3	Protective class I – Protective bonding and earthing		P
7.3.6.3.1	General		P
	Equipment of protective class I shall be provided with protective earthing, and with protective bonding to ensure electrical contact between accessible conductive parts and the means of connection for the external protective earthing conductor, except bonding is not required for:		P
	a) accessible conductive parts that are protected by one of the measures in 7.3.5.2 to 7.3.5.4, or		N/A
	b) accessible conductive parts are separated from live parts of DVC-B or -C using double or reinforced insulation.		N/A
7.3.6.3.2	Requirements for protective bonding		P
	Electrical contact with the means of connection of the external protective earthing conductor shall be achieved by one or more of the following means:	The earthing wire is reliably secured to internal metal enclosure	P
	a) through direct metallic contact;		P
	b) through other conductive parts which are not removed when the PCE or sub-units are used as intended ;		N/A
	c) through a dedicated protective bonding conductor;		P
	d) through other metallic components of the PCE		N/A
	Where direct metallic contact is used and one or both of the parts involved is painted or coated, the paint or coating shall be removed in the area of contact, or reliably penetrated, to ensure metal to metal contact.	The metal enclosure is reliably penetrated and earthed	P
	For moving or removable parts, hinges or sliding contacts designed and maintained to have a low resistance are examples of acceptable means if they comply with the requirements of 7.3.6.3.3.	No such design	N/A
	Metal ducts of flexible or rigid construction and metallic sheaths shall not be used as protective bonding conductors, unless the device or material has been investigated as suitable for protective	No such design	N/A

	bonding purposes.		
7.3.6.3.3	Rating of protective bonding		P
	<p>Protective bonding shall withstand the highest thermal and dynamic stresses that can occur to the PCE item(s) concerned when they are subjected to a fault connecting live parts to accessible conductive parts.</p> <p>The protective bonding shall remain effective for as long as a fault to the accessible conductive parts persists or until an upstream protective device removes power from the part.</p>		P
	Protective bonding shall meet following requirements:		P
	a) For PCE with an overcurrent protective device rating of 16 A or less, the impedance of the protective bonding means shall not exceed 0,1 Ω during or at the end of the test below.		N/A
	b) For PCE with an overcurrent protective device rating of more than 16 A, the voltage drop in the protective bonding test shall not exceed 2,5 V during or at the end of the test below.		P
	As alternative to a) and b) the protective bonding may designed according to the requirements for the external protective earthing conductor in 7.3.6.3.5, in which case no testing is required.	Test done	N/A
	The impedance of protective bonding means shall be checked by passing a test current through the bond for a period of time as specified below. The test current is based on the rating of the overcurrent protection for the equipment or part of the equipment under consideration, as follows:		P
	a) For pluggable equipment type A, the overcurrent protective device is that provided external to the equipment (for example, in the building wiring, in the mains plug or in an equipment rack);		N/A
	b) For pluggable equipment type B and fixed equipment, the maximum rating of the overcurrent protective device specified in the equipment installation instructions to be provided external to the equipment;		P
	c) For a circuit or part of the equipment for which an overcurrent protective device is provided as part of the equipment, the rating of the provided overcurrent device.	Internal RCM remove power if earth fault happens	P
	Voltages are measured from the protective earthing terminal to all parts whose protective bonding means are being considered. The impedance of the protective earthing conductor is not included in the measurement. However, if the protective earthing conductor is supplied with the equipment, it is permitted to include the conductor in the test circuit but the measurement of the voltage drop is made only from the main protective earthing terminal to the accessible part required to be earthed.	Measured form the farthest part of earthed metal enclosure to the input earth terminal	P

	On equipment where the protective earth connection to a subassembly or to a separate unit is part of a cable that also supplies power to that subassembly or unit, the resistance of the protective bonding conductor in that cable is not included in the protective bond impedance measurements for the subassembly or separate unit, as shown in Figure 11. However, this option is only permitted if the cable is protected by a suitably rated protective device that takes into account the size of the conductor. Otherwise the impedance of the protective bonding conductor between the separate units is to be included, by measuring to the protective earthing terminal where the power source enters the first unit in the system, as shown in Figure 12.		P
7.3.6.3.3.1	Test current, duration, and acceptance criteria		P
	The test current, duration of the test and acceptance criteria are as follows:		P
	a) For PCE with an overcurrent protective device rating of 16 A or less, the test current is 200% of the overcurrent protective device rating, but not less than 32 A, applied for 120s. The impedance of the protective bonding means during and at the end of the test shall not exceed 0,1 Ω .		N/A
	b) For PCE with an overcurrent protective device rating of more than 16 A, the test current is 200% of the overcurrent protective device rating and the duration of the test is as shown in Table 10 below. The voltage drop in the protective bonding means, during and at the end of the test, shall not exceed 2,5 V.	0.12V	P
	c) During and after the test, there shall be no melting, loosening, or other damage that would impair the effectiveness of the protective bonding means.		P
	The test current is derived from an a.c or d.c supply source, the output of which is not earthed.		P
	As an alternative to Table 10, where the time-current characteristic of the overcurrent protective device that limits the fault current in the protective bonding means is known because the device is either provided in the equipment or fully specified in the installation instructions, the test duration may be based on that specific device's time-current characteristic,. The tests are conducted for a duration corresponding to the 200% current value on the time-current characteristic.		N/A
7.3.6.3.4	Protective bonding impedance (routine test)	Manufacture declaration for this and with FI	N/A
	If the continuity of the protective bonding is achieved at any point by a single means only (for example a single conductor or single fastener), or if the PCE is assembled at the installation location, then the impedance of the protective bonding shall		N/A

	also be tested as a routine test. The test shall be as in 7.3.6.3.3, except for the following:		
	<ul style="list-style-type: none"> the test current may be reduced to any convenient value greater than 10 A sufficient to allow measurement or calculation of the impedance of the protective bonding means: 		N/A
	<ul style="list-style-type: none"> the test duration may be reduced to no less than 2 s 		N/A
	For equipment subject to the type test in 7.3.6.3.3.1a), the impedance during the routine test shall not exceed 0,1Ω.		N/A
	For equipment subject to the type test in 7.3.6.3.3.1b) the impedance during the routine test shall not exceed 2,5 V divided by the test current required by 7.3.6.3.3.1b).		N/A
7.3.6.3.5	External protective earthing conductor		P
	A protective earthing conductor shall be connected at all times when power is supplied to PCE of protective class I. Unless local wiring regulations state otherwise, the protective earthing conductor cross-sectional area shall be determined from Table 11 or by calculation according to IEC 60364-5-54.	<p>Phase conductors: EVVO 50000TL3P EVVO 60000TL3P >10mm²</p> <p>EVVO 70000TL3P-HV >16mm²</p> <p>Internal&External protective earthing conductor: EVVO 50000TL3P EVVO 60000TL3P >10mm²</p> <p>EVVO 70000TL3P-HV >16mm²</p>	P
	If the external protective earthing conductor is routed through a plug and socket or similar means of disconnection, it shall not be possible to disconnect it unless power is simultaneously removed from the part to be protected.	Permanently connected	N/A
	The cross-sectional area of every external protective earthing conductor which does not form part of the supply cable or cable enclosure shall, in any case, be not less than:		P
	<ul style="list-style-type: none"> 2,5 mm² if mechanical protection is provided; 		N/A
	<ul style="list-style-type: none"> 4 mm² if mechanical protection is not provided. 	The installation manual require min 4mm ² wire	P
	For cord-connected equipment, provisions shall be made so that the external protective earthing conductor in the cord shall, in the case of failure of the strain-relief mechanism, be the last conductor to be interrupted.	Not cord-connected equipment.	N/A
7.3.6.3.6	Means of connection for the external protective earthing conductor		P
7.3.6.3.6.1	General		P

	<p>The means of connection for the external protective earthing conductor shall be located near the terminals for the respective live conductors. The means of connections shall be corrosion-resistant and shall be suitable for the connection of cables according to 7.3.6.3.5.</p> <p>The means of connection for the protective earthing conductor shall not be used as a part of the mechanical assembly of the equipment or for other connections.</p> <p>A separate means of connection shall be provided for each external protective earthing conductor.</p> <p>Connection and bonding points shall be so designed that their current-carrying capacity is not impaired by mechanical, chemical, or electrochemical influences. Where enclosures and/or conductors of aluminium or aluminium alloys are used, particular attention should be given to the problems of electrolytic corrosion.</p>		P
	The means of connection for the protective earthing conductor shall be permanently marked with:		P
	<ul style="list-style-type: none"> • symbol 7 of Annex C; or 		P
	<ul style="list-style-type: none"> • the colour coding green-yellow 		N/A
	Marking shall not be done on easily changeable parts such as screws.		P
7.3.6.3.7	Touch current in case of failure of the protective earthing conductor		P
	The requirements of this sub-clause shall be satisfied to maintain safety in case of damage to or disconnection of the protective earthing conductor.		P
	For pluggable equipment type A, the touch current measured in accordance with 7.5.4 shall not exceed 3,5 mA a.c. or mA d.c.		P
	For all other PCE, one or more of the following measure shall be applied, unless the touch current measured in accordance with 7.5.4 using the test network of IEC 60990 test figure 4 shall not exceed 3,5 mA a.c. or 10 mA d.c.	1.094 mA a.c. max.	P
	a) Permanently connected wiring, and:	Not exceed 3.5mA a.c.	N/A
	<ul style="list-style-type: none"> • a cross-section of the protective earthing conductor of at least 10 mm² Cu or 16 mm² Al; or 		N/A
	<ul style="list-style-type: none"> • automatic disconnection of the supply in case of discontinuity of the protective earthing conductor; or 		N/A
	<ul style="list-style-type: none"> • provision of an additional terminal for a second protective earthing conductor of the same cross-sectional area as the original protective earthing conductor and installation instruction requiring a second protective earthing conductor to be installed or 		N/A

	b) Connection with an industrial connector according to IEC 60309 and a minimum protective earthing conductor cross-section of 2,5 mm ² as part of a multi-conductor power cable. Adequate strain relief shall be provided.	Not exceed 3.5mA a.c.	N/A
	In addition, the caution symbol 15 of Annex C shall be fixed to the product and the installation manual shall provide details of the protective earthing measures required in the installation as required in 5.3.2.		N/A
	When it is intended and allowed to connect two or more PCEs in parallel using one common PE conductor, the above touch current requirements apply to the maximum number of the PCEs to be connected in parallel, unless one of the measures in a)		N/A
	or b) above is used. The maximum number of parallel PCEs is used in the testing and has to be stated in the installation manual.		N/A
7.3.6.4	Protective Class II – Double or Reinforced Insulation	Signal communication port are evaluated with reinforced insulation form live parts inside	P
	Equipment or parts of equipment designed for protective class II shall have insulation between live parts and accessible surfaces in accordance with 7.3.4.3. The following requirements also apply:		P
	<ul style="list-style-type: none"> equipment designed to protective class II shall not have means of connection for the external protective earthing conductor. However this does not apply if the external protective earthing conductor is passed through the equipment to equipment series-connected beyond it. In the latter event, the external protective earthing conductor and its means for connection shall be insulated with basic insulation from the accessible surface of the equipment and from circuits that employ protective separation, extra-low voltage, protective impedance and limited discharging energy, according to 7.3.5. This basic insulation shall correspond to the rated voltage of the series-connected equipment; 		N/A
	<ul style="list-style-type: none"> metal-encased equipment of protective class II may have provision on its enclosure for the connection of an equipotential bonding conductor; 		N/A
	<ul style="list-style-type: none"> equipment of protective class II may have provision for the connection of an earthing conductor for functional reasons or for damping of overvoltages; it shall, however, be insulated as though it is a live part; 		N/A
	<ul style="list-style-type: none"> equipment employing protective class II shall be marked according to 5.1.8. 		N/A
7.3.7	Insulation Including Clearance and Creepage		P

	Distance		
7.3.7.1	General		P
	This subclause gives minimum requirements for insulation, based on the principles of IEC 60664.		P
	Manufacturing tolerances shall be taken into account during measurement of creepage, clearance, and insulation distance in the PCE.		P
	Insulation shall be selected after consideration of the following influences:		P
	<ul style="list-style-type: none"> • pollution degree 	PD3 outside. PD2 inside	P
	<ul style="list-style-type: none"> • overvoltage category 	PV (OVC II), Main(OVC III)	P
	<ul style="list-style-type: none"> • supply earthing system 	TN	P
	<ul style="list-style-type: none"> • insulation voltage 	PV input: max. 1000Vdc and Main:230/400Vac	P
	<ul style="list-style-type: none"> • location of insulation 	See table 7.3.7.4 and 7.3.7.5 for detail	P
	<ul style="list-style-type: none"> • type of insulation 	See table 7.3.7.4 and 7.3.7.5 for detail	P
	Compliance of insulation, creepage distances, and clearance distances, shall be verified by measurement or visual inspection, and the tests of 7.5.		P
7.3.7.1.3	Supply earthing systems		P
	Three basic types of earthing system are described in IEC 60364-1. They are:	Inverter is intended to installed in TN system	P
	<ul style="list-style-type: none"> • TN system: has one point directly earthed, the accessible conductive parts of the installation being connected to that point by protective conductors. Three types of TN systems, TN-C, TN-S and TN-C-S, are defined according to the arrangement of the neutral and protective conductor. 		P
	<ul style="list-style-type: none"> • TT system: has one point directly earthed, the accessible conductive parts of the installation being connected to earth electrodes electrically independent of the earth electrodes of the power system; 		N/A
	<ul style="list-style-type: none"> • IT system: has all live parts isolated from earth or one point connected to earth through an impedance, the accessible conductive parts of the installation being earthed independently or collectively to the earthing system. 		N/A
7.3.7.1.4	Insulation voltages	See table 7.3.7.4 and 7.3.7.5 for detail	P
	Table 12 makes use of the circuit system voltage and overvoltage category to define the impulse withstands voltage and the temporary overvoltage.		P
7.3.7.2	Insulation between a circuit and its surroundings		P
7.3.7.2.1	General	600V, OVC III (6000V impulse voltage, 1500Vrms temporary overvoltage) for the AC output terminal.	P

		1000V, OVC II (6000V impulse voltage, no temporary overvoltage) for PV input terminal. No isolation between PV and AC main output. Maximum 1000Vdc working voltage is assumed at DVC A circuit and DVC C circuit	
7.3.7.2.2	Circuits connected directly to the mains	System voltage for mains is 600Vrms according to table 12	P
7.3.7.2.3	Circuits other than mains circuits	System voltage for PV is 1000Vdc.	P
7.3.7.2.4	Insulation between circuits	6000V impulse voltage, 2030Vdc temporary overvoltage is calculated from table 12 for clearance. 1000Vdc working voltage across insulation is used for creepage	P
7.3.7.3	Functional insulating		P
7.3.7.4	Clearance distances	(see appended table 7.3.7)	P
7.3.7.4.1	Determination		P
7.3.7.4.2	Electric field homogeneity	Inhomogeneous electric field is considered for PCE	N/A
7.3.7.4.3	Clearance to conductive enclosures		P
7.3.7.5	Creepage distances	(see appended table 7.3.7)	P
7.3.7.5.1	General	PV maximum 1000V system voltage is used for the RMS voltage across insulation	P
7.3.7.5.2	Voltage	If Working voltage less than system voltage, system voltage is used for creepage according to IEC60664-1	P
7.3.7.5.3	Materials	Certified PWB used. Other materials are considered IIIb. The inside part are considered Pollution degree 2	P
7.3.7.6	Coating		N/A
7.3.7.7	PWB spacings for functional insulating	V-0 and short circuit test are considered	P
7.3.7.8	Solid insulating	(see appended table 7.3.7)	P
7.3.7.8.1	General		P
7.3.7.8.2	Requirements for electrical withstand capability of solid insulation		P
7.3.7.8.2.1	Basic, supplemental, reinforced, and double insulation	1000V peak. Impulse voltage test and voltage test are considered for solid insulation.	P
7.3.7.8.2.2	Functional insulation		P
7.3.7.8.3	Thin sheet or tape material		P
7.3.7.8.3.1	General		P
7.3.7.8.3.2	Material thickness not less than 0,2 mm	Impulse test and voltage test are considered for insulation	P

		on IGBT as basic insulation	
7.3.7.8.3.3	Material thickness less than 0,2 mm		N/A
7.3.7.8.3.4	Compliance		N/A
7.3.7.8.4	Printed wiring boards		P
7.3.7.8.4.1	General	Four layers PWB	P
7.3.7.8.4.2	Use of coating materials		N/A
7.3.7.8.5	Wound components	Varnish is not considered as insulation and voltage test performed as routine test.	P
7.3.7.8.6	Potting materials		N/A
7.3.7.9	Insulation requirements above 30 kHz		N/A
7.3.8	Residual Current-operated protective (RCD) or monitoring (RCM) device compatibility	Internal RCM is used. An external built RCD is not necessary	P
	RCD and RCM are used to provide protection against insulation faults in some domestic and industrial installations, additional to that provided by the installed equipment.		N/A
7.3.9	Capacitor discharge		P
7.3.9.1	Operator access area	Accessible signal communication port is DVA circuit.	P
	Equipment shall be so designed that there is no risk of electric shock in operator access areas from charge stored on capacitors after disconnection of the PCE.		P
7.3.9.2	Service access areas	Inside capacitor discharge to DVC A and no energy hazard level within 300s	P
	Capacitors located behind panels that are removable for servicing, installation, or disconnection shall present no risk of electric shock or energy hazard from charge stored on capacitors after disconnection of the PCE.	Warning symbol 21 of annex C is marked on PCE with 5min.	P
7.4	Protection against energy hazards		P
7.4.1	Determination of hazardous energy level	No such high energy level presented in the operator access area.	P
	A hazardous energy level is considered to exist if		P
	a) The voltage is 2 V or more, and power available after 60 s exceeds 240 VA.		N/A
	b) The stored energy in a capacitor is at a voltage. U of 2 V or more, and the stored energy. E, calculated from the following equation, exceeds 20J: $E = 0,5 CU^2$	Communication port : 5.76V, 1.11mA. No cap.	P
7.4.2	Operator Access Areas	No energized parts accessibel by user	P
	Equipment shall be so designed that there is no risk of energy hazard in operator access areas from accessible circuits.		P

7.4.3	Services Access Areas		P
7.5	Electrical tests related to shock hazard	(see appended table 7.5)	P
7.5.1	Impulse voltage test (type test)		P
7.5.2	Voltage test (dielectric strength test)		P
7.5.2.1	Purpose of test		P
7.5.2.2	Value and type of test voltage		P
7.5.2.3	Humidity pre-conditioning		P
7.5.2.4	Performing the voltage test		P
7.5.2.5	Duration of the a.c. or d.c. voltage test		P
7.5.2.6	Verification of the a.c. or d.c. voltage test		P
7.5.3	Partial discharge test	(see appended table 7.5)	P
7.5.4	Touch current measurement (type test)		P
	The touch current shall be measured if required by 7.3.6.3.7 and shall not be greater than 3.5 mA a.c. or 10 mA d.c. or special measures of protection as given in 7.3.6.3.7 are required.	(see appended table 7.3.6.3.7)	P
	For type tests on PCE for which wet locations requirements apply according to 6.1, the humidity pre-conditioning of 4.5 shall be performed immediately prior to the touch current test.		P
7.5.5	Equipment with multiple sources of supply		P
8	PROTECTION AGAINST MECHANICAL HAZARDS		P
8.1	General		--
	Operation shall not lead to a mechanical HAZARD in NORMAL CONDITION or SINGLE FAULT CONDITION. Edges, projections, corners, openings, guards, handles and the like, that are accessible to the operator shall be smooth and rounded so as not to cause injury during normal use of the equipment.		P
	Conformity is checked as specified in 8.2 to 8.6.		P
8.2	Moving parts		N/A
	Moving parts shall not be able to crush, cut or pierce parts of the body of an OPERATOR likely to contact them, nor severely pinch the OPERATOR's skin. Hazardous moving parts of equipment, that is moving parts which have the potential to cause injury, shall be so arranged, enclosed or guarded as to provide adequate protection against the risk of personal injury.	No moving parts	N/A
8.2.1	Protection of service persons		P
	Protection shall be provided such that unintentional contact with hazardous moving parts is unlikely during servicing operations. If a guard over a hazardous moving part may need to be removed for servicing, the marking of symbol 15 of Table D-1 shall be applied on or near the guard.		P

8.3	Stability		N/A
	Equipment and assemblies of equipment not secured to the building structure before operation shall be physically stable in NORMAL USE.	Wall mounted	N/A
8.4	Provisions for lifting and carrying		P
	If carrying handles or grips are fitted to, or supplied with, the equipment, they shall be capable of withstanding a force of four times the weight of the equipment.		P
	Equipment or parts having a mass of 18 kg or more shall be provided with a means for lifting and carrying or directions shall be given in the manufacturer's documentation.		P
8.5	Wall mounting		P
	Mounting brackets on equipment intended to be mounted on a wall or ceiling shall withstand a force of four times the weight of the equipment.		P
8.6	Expelled parts		N/A
	Equipment shall contain or limit the energy of parts that could cause a HAZARD if expelled in the event of a fault.		N/A
9	PROTECTION AGAINST FIRE HAZARDS		P
9.1	Resistance to fire		P
	This subclause specifies requirements intended to reduce the risk of ignition and the spread of flame, both within the equipment and to the outside, by the appropriate use of materials and components and by suitable construction.	Components are witnessed at normal condition and abnormal test are verified	P
9.1.1	Reducing the risk of ignition and spread of flame		P
	For equipment or a portion of equipment, there are two alternative methods of providing protection against ignition and spread of flame that could affect materials, wiring, wound components and electronic components such as integrated circuits, transistors, thyristors, diodes, resistors and capacitors.	Method 1 used	P
9.1.2	Conditions for a fire enclosure		P
	A FIRE ENCLOSURE is required for equipment or parts of equipment for which Method 2 is not fully applied and complied with.		P
9.1.2.1	Parts requiring a fire enclosure		P
	Except where Method 2 is used, or as permitted in 9.1.2.2, the following are considered to have a risk of ignition and, therefore, require a FIRE ENCLOSURE:		P
	– components in PRIMARY CIRCUITS		P
	– components in SECONDARY CIRCUITS supplied by power sources which exceed the limits for a LIMITED POWER SOURCE as specified in 9.2;		P

	– components in SECONDARY CIRCUITS supplied by a LIMITED POWER SOURCE as specified in 9.2, but not mounted on a material of FLAMMABILITY CLASS V-1;	PWB rated V-0	N/A
	– components within a power supply unit or assembly having a limited power output complying with the criteria for a LIMITED POWER SOURCE as specified in 9.2, including overcurrent protective devices, limiting impedances, regulating networks and wiring, up to the point where the LIMITED POWER SOURCE output criteria are met;		P
	– components having unenclosed arcing parts, such as open switch and relay contacts and commutators, in a circuit at HAZARDOUS VOLTAGE or at a HAZARDOUS ENERGY LEVEL; and	Certified relay	N/A
	– insulated wiring, except as permitted in 9.1.2.2.	PVC wire	N/A
9.1.2.2	Parts not requiring a fire enclosure	Fire enclosure used	N/A
9.1.3	Materials requirements for protection against fire hazard		P
9.1.3.1	General		P
	ENCLOSURES, components and other parts shall be so constructed, or shall make use of such materials, that the propagation of fire is limited.		P
9.1.3.2	Materials for fire enclosures	Metal fire enclosure	P
	If an enclosure material is not classified as specified below, a test may be performed on the final enclosure or part of the enclosure, in which case the material shall additionally be subjected to periodic SAMPLE testing.		P
9.1.3.3	Materials for components and other parts outside fire enclosures		P
	Except as otherwise noted below, materials for components and other parts (including MECHANICAL ENCLOSURES, ELECTRICAL ENCLOSURES and DECORATIVE PARTS); located outside FIRE ENCLOSURES, shall be of FLAMMABILITY CLASS HB.	Internal wire:VW-1 PWB: V-0	P
9.1.3.4	Materials for components and other parts inside fire enclosures		N/A
9.1.3.5	Materials for air filter assemblies		N/A
9.1.4	Openings in fire enclosures	No openings	N/A
9.1.4.1	General		N/A
	For equipment that is intended to be used or installed in more than one orientation as specified in the product documentation, the following requirements apply in each orientation.		N/A
	These requirements are in addition to those in the following sections:		N/A

	– 7.3.4, Protection against direct contact;		N/A
	– 7.4, Protection against energy hazards;		N/A
	– 13.5, Openings in enclosures		N/A
9.1.4.2	Side openings treated as bottom openings		N/A
9.1.4.3	Openings in the bottom of a fire enclosure		N/A
	The bottom of a FIRE ENCLOSURE or individual barriers, shall provide protection against emission of flaming or molten material under all internal parts, including partially enclosed components or assemblies, for which Method 2 of 9.1.1 has not been fully applied and complied with.		N/A
9.1.4.4	Equipment for use in a CLOSED ELECTRICAL OPERATING AREA		N/A
	The requirements of 9.1.4.3 do not apply to FIXED EQUIPMENT intended only for use in a CLOSED ELECTRICAL OPERATING AREA and to be mounted on a concrete floor or other non-combustible surface. Such equipment shall be marked as follows:		N/A
	WARNING: FIRE HAZARD SUITABLE FOR MOUNTING ON CONCRETE OR OTHER NON-COMBUSTIBLE SURFACE ONLY		N/A
9.1.4.5	Doors or covers in fire enclosures	No door or cover operated by user	N/A
9.1.4.6	Additional requirements for openings in transportable equipment		N/A
9.2	LIMITED POWER SOURCES		N/A
9.2.1	General		N/A
9.2.2	Limited power source tests	(see appended table 9.2)	N/A
9.3	Short-circuit and overcurrent protection		P
9.3.1	General		P
	The PCE shall not present a hazard, under short-circuit or overcurrent conditions at any port, including phase-to-phase, phase-to-earth and phase-to-neutral, and adequate information shall be provided to allow proper selection of external wiring and external protective devices.		P
9.3.2	Protection against short-circuits and overcurrents shall be provided for all input circuits, and for output circuits that do not comply with the requirements for limited power sources in 9.2, except for circuits in which no overcurrent hazard is presented by short-circuits and overloads.	AC main fuse protect the AC wire and DC wire are designed for the short circuit rating of the array	P
9.3.3	Protective devices provided or specified shall have adequate breaking capacity to interrupt the maximum short circuit current specified for the port to which they are connected. If protection that is provided integral to the PCE for an input port is not rated for the short-circuit current of the circuit in which it is used, the installation instructions shall specify that an upstream protective device, rated	AC fuse integral to PCE	P

	for the prospective short-circuit current of that port, shall be used to provide backup protection.		
--	---	--	--

10	PROTECTION AGAINST SONIC PRESSURE HAZARDS		P
10.1	General		P
	The equipment shall provide protection against the effect of sonic pressure. Conformity tests are carried out if the equipment is likely to cause such HAZARDS.	No hazardous noise when operating.	P
10.2	Sonic pressure and Sound level		P
10.2.1	Hazardous Noise Levels	62dB	P

11	PROTECTION AGAINST LIQUID HAZARDS		N/A
11.1	Liquid Containment, Pressure and Leakage	No liquid containment system	N/A
	The liquid containment system components shall be compatible with the liquid to be used.		N/A
	There shall be no leakage of liquid onto live parts as a result of:		N/A
	a) Normal operation, including condensation;		N/A
	b) Servicing of the equipment; or		N/A
	c) Inadvertent loosening or detachment of hoses or other cooling system parts over time.		N/A
11.2	Fluid pressure and leakage		N/A
11.2.1	Maximum pressure		N/A
11.2.2	Leakage from parts		N/A
11.2.3	Overpressure safety device		N/A
11.3	Oil and grease		N/A

12	CHEMICAL HAZARDS		N/A
12.1	General		N/A

13	PHYSICAL REQUIREMENTS		P
13.1	Handles and manual controls		N/A
	Handles, knobs, grips, levers and the like shall be reliably fixed so that they will not work loose in normal use, if this might result in a hazard. Sealing compounds and the like, other than self-hardening resins, shall not be used to prevent loosening. If handles, knobs and the like are used to indicate the position of switches or similar components, it shall not be possible to fix them in a wrong position if this might result in hazard.		N/A
13.1.1	Adjustable controls	No such setting control	N/A
13.2	Securing of parts		P
13.3	Provisions for external connections		P

13.3.1	General		--
13.3.2	Connection to an a.c. Mains supply	An industrial AC connector used and it is detachable with tool	P
13.3.2.1	General		P
	For safe and reliable connection to a MAINS supply, equipment shall be provided with one of the following:	Certified PV connectors are used. AC terminal provided for grid connection and secured by a cable gland. Installation manual provide information for the disconnection means	P
	– terminals or leads or a non-detachable power supply cord for permanent connection to the supply; or		P
	– a non-detachable power supply cord for connection to the supply by means of a plug		N/A
	– an appliance inlet for connection of a detachable power supply cord; or		N/A
	– a mains plug that is part of direct plug-in equipment as in 13.3.8		N/A
13.3.2.2	Permanently connected equipment		P
13.3.2.3	Appliance inlets		N/A
13.3.2.4	Power supply cord		N/A
13.3.2.5	Cord anchorages and strain relief	Cable gland used	P
	For equipment with a non-detachable power supply cord, a cord anchorage shall be supplied such that:		P
	– the connecting points of the cord conductors are relieved from strain; and		P
	– the outer covering of the cord is protected from abrasion.		P
13.3.2.6	Protection against mechanical damage		P
13.3.3	Wiring terminals for connection of external conductors		P
13.3.3.1	Wiring terminals		P
13.3.3.2	Screw terminals		P
13.3.3.3	Wiring terminal sizes		P
13.3.3.4	Wiring terminal design		P
13.3.3.5	Grouping of wiring terminals		P
13.3.3.6	Stranded wire		P
13.3.4	Supply wiring space		N/A
13.3.5	Wire bending space for wires 10 mm ² and greater		N/A
13.3.6	Disconnection from supply sources	Installation manual instruct the disconnect device when connection AC main	P
13.3.7	Connectors, plugs and sockets		P
13.3.8	Direct plug-in equipment		N/A

13.4	Internal wiring and connections		P
13.4.1	General		P
13.4.2	Routing	Internal wire is routed to avoid sharp edge and overheat	P
13.4.3	Colour coding	Green-yellow wire used as protective bonding only	P
13.4.4	Splices and connections		P
13.4.5	Interconnections between parts of the PCE		P
13.5	Openings in enclosures		N/A
13.5.1	Top and side openings	No openings in enclosure	N/A
	Openings in the top and sides of ENCLOSURES shall be so located or constructed that it is unlikely that objects will enter the openings and create hazards by contacting bare conductive parts.		N/A
13.6	Polymeric Materials		P
13.6.1	General		P
13.6.1.1	Thermal index or capability		P
13.6.2	Polymers serving as enclosures or barriers preventing access to hazards		P
13.6.2.1	Stress relief test		N/A
13.6.3	Polymers serving as solid insulation		P
13.6.3.1	Resistance to arcing		N/A
13.6.4	UV resistance		P
	Polymeric parts of an OUTDOOR ENCLOSURE required for compliance with this standard shall be sufficiently resistance to degradation by ultra-violet (UV) radiation	The enclosure of the unit is made of metal with painting and the plastic window frame rated UV resistance according to UL 746C	P
13.7	Mechanical resistance to deflection, impact, or drop		P
13.7.1	General		P
13.7.2	250-N deflection test for metal enclosures		P
13.7.3	7-J impact test for polymeric enclosures		P
13.7.4	Drop test		N/A
13.8	Thickness requirements for metal enclosures		P
13.8.1	General		P
13.8.2	Cast metal		N/A
13.8.3	Sheet metal		P

14	COMPONENTS		P
14.1	General	(see appended table 14)	P
	Where safety is involved, components shall be used in accordance with their specified RATINGS unless a specific exception is made. They shall conform to one of the following:		P

	a) applicable safety requirements of a relevant IEC standard. Conformity with other requirements of the component standard is not required. If necessary for the application, components shall be subjected to the test of this standard, except that it is not necessary to carry out identical or equivalent tests already performed to check conformity with the component standard;		P
	b) the requirements of this standard and, where necessary for the application, any additional applicable safety requirements of the relevant IEC component standard;		P
	c) if there is no relevant IEC standard, the requirements of this standard;		P
	d) applicable safety requirements of a non-IEC standard which are at least as high as those of the applicable IEC standard, provided that the component has been approved to the non-IEC standard by a recognized testing authority.		P
	Components such as optocouplers, capacitors, transformers, and relays connected across basic, supplemental, reinforced, or double insulation shall comply with the requirements applicable for the grade of insulation being bridged, and if not previously certified to the applicable component safety standard shall be subjected to the voltage test of 7.5.2 as routine test.		P
14.2	Motor Over temperature Protection		N/A
	Motors which, when stopped or prevented from starting (see 4.4.4.3), would present an electric shock HAZARD, a temperature HAZARD, or a fire HAZARD, shall be protected by an over temperature or thermal protection device meeting the requirements of 14.3.	No motor	N/A
14.3	Over temperature protection devices		N/A
14.4	Fuse holders		N/A
14.5	MAINS voltage selecting devices		N/A
14.6	Printed circuit boards		P
	Printed circuit boards shall be made of material with a flammability classification of V-1 of IEC 60707 or better.	V-0	P
	This requirement does not apply to thin-film flexible printed circuit boards that contain only circuits powered from limited power sources meeting the requirements of 9.2.		P
	Conformity of the flammability RATING is checked by inspection of data on the materials. Alternatively, conformity is checked by performing the V-1 tests specified in IEC 60707 on three samples of the relevant parts.		P
14.7	Circuits or components used as transient overvoltage limiting devices		N/A

	If control of transient overvoltage is employed in the equipment, any overvoltage limiting component or circuit shall be tested with the applicable impulse withstand voltage of Table 7-10 using the test method from 7.5.1 except 10 positive and 10 negative impulses are to be applied and may be spaced up to 1 min apart.		N/A
14.8	Batteries		N/A
	Equipment containing batteries shall be designed to reduce the risk of fire, explosion and chemical leaks under normal conditions and after a single fault in the equipment including a fault in circuitry within the equipment battery pack.		N/A
14.8.1	Battery Enclosure Ventilation		N/A
14.8.1.1	Ventilation requirements		N/A
14.8.1.2	Ventilation testing		N/A
14.8.1.3	Ventilation instructions		N/A
14.8.2	Battery Mounting		N/A
	Compliance is verified by the application of the force to the battery's mounting surface. The test force is to be increased gradually so as to reach the required value in 5 to 10 s, and is to be maintained at that value for 1 min. A non-metallic rack or tray shall be tested at the highest normal condition operating temperature.		N/A
14.8.3	Electrolyte spillage		N/A
	Battery trays and cabinets shall have an electrolyte-resistant coating.		N/A
	The ENCLOSURE or compartment housing a VENTED BATTERY shall be constructed so that spillage or leakage of the electrolyte from one battery will be contained within the ENCLOSURE and be prevented from:		N/A
	a) reaching the PCE outer surfaces that can be contacted by the USER		N/A
	b) contaminating adjacent electrical components or materials; and		N/A
	c) bridging required electrical distances		N/A
14.8.4	Battery Connections		N/A
	Reverse battery connection of the terminals shall be prevented if reverse connection could result in a hazard within the meaning of this Standard		N/A
14.8.5	Battery maintenance instructions		N/A
	The information and instructions listed in 5.3.4.1 shall be included in the operator manual for equipment in which battery maintenance is performed by the operator, or in the service manual if battery maintenance is to be performed by service personnel only.		N/A
14.8.6	Battery accessibility and maintainability		N/A

	Battery terminals and connectors shall be accessible for maintenance with the correct TOOLS. Batteries with liquid electrolyte, requiring maintained shall be so located that the battery cell caps are accessible for electrolyte tests and readjusting of electrolyte levels.		N/A
15	Software and firmware performing safety functions		P

4.2.2.6	TABLE: : electrical data Output side (Grid connection)						P
Type	U ac (V)	I acmax (A)	P (kW)	f (HZ)	--	--	
EVVO 60000TL3P (phase A)	231.1	85.3	19675	49.99	--	--	
EVVO 60000TL3P (phase B)	231.3	86.5	19956	49.99	--	--	
EVVO 60000TL3P (phase C)	231.2	88.4	20401	49.99	--	--	
EVVO 70000TL3P-HV (phase A)	277.1	83.3	23042	49.99	--	--	
EVVO 70000T39L-HV (phase B)	277.1	84.0	23249	49.99	--	--	
EVVO 70000TL3P-HV (phase C)	277.2	86.9	24060	49.99	--	--	
Supplementary information: N/A							

4.2.2.7	TABLE: electrical data Input side (PV – Generator)						P
Type	U dcmax (V)	U dcmin (V)	U mppmin (V)	U mppmax (V)	I dcmax (A)	Pmax (kW)	
EVVO 60000TL3P	1000	--	--	--	0	0	
	--	250	--	--	20.0	5.0	
	--	--	530	--	119.3	63.240	
	--	--	--	800	80.3	64.220	
EVVO 70000TL3P-HV	1000	--	--	--	0	0	
	--	250	--	--	20.0	5.0	
	--	--	660	--	111.0	73.240	
	--	--	--	800	92.8	74.226	
Supplementary information: U dcmax is 1000V. It is open circuit voltage. At this condition, PV inverter cannot work.							

4.3 a)	TABLE: heating temperature rise measurements					P
	test voltage (V)			Input: 660Vdc Output: 230Vac		—
	t1 (°C)			44.4		—
	t2 (°C)			44.4		—
Thermocouple Locations	Max. temperature measured (°C)			Max. temperature limit (°C)		
Boost Inductor 1	65.6			110		
INV inductor R	77.0			110		
E-capacitor ECD16	69.9			105		
Drive optocoupler UV2	96.7			105		
Drive transformer TXD1	87.0			110		
Film capacitor CD18	79.6			105		
IGBT Module T	110.9			150		
DD30	90.3			150		
MOSFET DD14	99.8			150		
DC switch	47.9			85		
PV connector	59.4			85		
Input wire	80.2			105		
PCB of Power board	105.1			130		
Capacitor CD47	85.1			105		
Y capacitor CF18	73.1			105		
Film capacitor CAS21	77.1			105		
MOVF6	77.5			85		
Input Inductor LA2	79.9			110		
Film capacitor CA23	66.8			105		
Current sensor HCTA2	78.2			85		
ISO Relay RYA2	76.7			85		
Internal Fan	75.5			85		
MOSFET QC5	85.7			150		
SPS transformer TC1 coil	79.0			110		
Inductor LB6	76.6			110		
Film capacitor CB50	76.1			105		
Output CT HCTB1	83.3			85		
Output Relay RY3B	82.3			85		
Inductor LB1	83.9			110		
MOVB2	75.6			85		
X capacitor CB3	74.1			110		
CYB5A Y Cap	73.4			110		
Output wire	81.5			105		
Inductor LB2	80.3			110		
AC Connector	72.8			85		
Outside fan	54.4			85		
Display	70.6			85		
Heatsink / mounting surface	57.9			100		
	TABLE: Heating test, resistance method					
	Test voltage (V)					—
	Ambient, t ₁ (°C)					—
	Ambient, t ₂ (°C)					—
Temperature rise of winding	R ₁ (Ω)	R ₂ (Ω)	ΔT (K)	Max. dT (K)	Insulation class	

Supplementary information:					
4.3 b)	TABLE: heating temperature rise measurements				P
	test voltage (V)	Input: 800Vdc Output: 230Vac		—	
	t1 (°C)	44.8		—	
	t2 (°C)	45.8		—	
Thermocouple Locations		Max. temperature measured (°C)		Max. temperature limit (°C)	
Boost Inductor 1		46.0		110	
INV inductor R		78.4		110	
E-capacitor ECD16		65.6		105	
Drive optocoupler UV2		92.9		105	
Drive transformer TXD1		81.7		110	
Film capacitor CD18		75.9		105	
IGBT Module T		110.1		150	
DD30		65.0		150	
MOSFET DD14		68.3		150	
DC switch		44.5		85	
PV connector		55.5		85	
Input wire		74.1		105	
PCB of Power board		97.4		130	
Capacitor CD47		72.9		105	
Y capacitor CF18		67.3		105	
Film capacitor CAS21		71.7		105	
MOV6		69.5		85	
Input Inductor LA2		73.0		110	
Film capacitor CA23		67.3		105	
Current sensor HCTA2		73.0		85	
ISO Relay RYA2		73.5		85	
Internal Fan		70.6		85	
MOSFET QC5		81.1		150	
SPS transformer TC1 coil		75.4		110	
Inductor LB6		74.3		110	
Film capacitor CB50		73.9		105	
Output CT HCTB1		81.0		85	
Output Relay RY3B		79.8		85	
Inductor LB1		82.9		110	
MOVB2		73.0		85	
X capacitor CB3		71.2		110	
CYB5A Y Cap		69.7		110	
Output wire		79.0		105	
Inductor LB2		77.9		110	
AC Connector		69.9		85	
Outside fan		51.5		85	
Display		66.9		85	
Heatsink / mounting surface		50.5		100	
TABLE: Heating test, resistance method					
	Test voltage (V).....				—
	Ambient, t₁(°C).....				—
	Ambient, t₂(°C).....				—
Temperature rise of winding	R₁(Ω)	R₂(Ω)	ΔT (K)	Max. dT (K)	Insulation class

Supplementary information:					
4.3 c)	TABLE: heating temperature rise measurements				P
	test voltage (V)	Input: 460Vdc Output: 253Vac		—	
	t1 (°C)	59.01		—	
	t2 (°C)	60.03		—	
Thermocouple Locations		Max. temperature measured (°C)		Max. temperature limit (°C)	
Boost Inductor 1		75.8		110	
INV inductor R		85.0		110	
E-capacitor ECD16		78.7		105	
Drive optocoupler UV2		103.3		105	
Drive transformer TXD1		93.3		110	
Film capacitor CD18		87.5		105	
IGBT Module T		114.1		150	
DD30		95.3		150	
MOSFET DD14		104.4		150	
DC switch		63.0		85	
PV connector		72.0		85	
Input wire		87.0		105	
PCB of Power board		107.0		130	
Capacitor CD47		92.2		105	
Y capacitor CF18		82.1		105	
Film capacitor CAS21		85.0		105	
MOVF6		82.5		85	
Input Inductor LA2		87.2		110	
Film capacitor CA23		82.1		105	
Current sensor HCTA2		78.7		85	
ISO Relay RYA2		75.3		85	
Internal Fan		82.5		85	
MOSFET QC5		95.1		150	
SPS transformer TC1 coil		89.8		110	
Inductor LB6		85.0		110	
Film capacitor CB50		84.1		105	
Output CT HCTB1		83.0		85	
Output Relay RY3B		81.8		85	
Inductor LB1		89.6		110	
MOVB2		83.9		85	
X capacitor CB3		82.7		110	
CYB5A Y Cap		82.4		110	
Output wire		89.3		105	
Inductor LB2		87.6		110	
AC Connector		81.5		85	
Outside fan		71.1		85	
Display		80.3		85	
Heatsink / mounting surface		71.9		100	
TABLE: Heating test, resistance method					
	Test voltage (V).....				—
	Ambient, t₁(°C).....				—
	Ambient, t₂(°C).....				—
Temperature rise of winding	R₁(Ω)	R₂(Ω)	ΔT (K)	Max. dT (K)	Insulation class

Supplementary information:					
4.3 d)	TABLE: heating temperature rise measurements				P
	test voltage (V)	Input: 460Vdc Output: 207Vac		—	
	t1 (°C)	59.01		—	
	t2 (°C)	60.03		—	
Thermocouple Locations		Max. temperature measured (°C)		Max. temperature limit (°C)	
Boost Inductor 1		62.5		110	
INV inductor R		87.0		110	
E-capacitor ECD16		76.3		105	
Drive optocoupler UV2		101.3		105	
Drive transformer TXD1		90.3		110	
Film capacitor CD18		85.9		105	
IGBT Module T		114.4		150	
DD30		76.8		150	
MOSFET DD14		80.4		150	
DC switch		61.4		85	
PV connector		69.5		85	
Input wire		83.4		105	
PCB of Power board		102.5		130	
Capacitor CD47		83.7		105	
Y capacitor CF18		78.8		105	
Film capacitor CAS21		82.0		105	
MOVF6		80.6		85	
Input Inductor LA2		83.1		110	
Film capacitor CA23		78.2		105	
Current sensor HCTA2		83.3		85	
ISO Relay RYA2		82.7		85	
Internal Fan		82.3		85	
MOSFET QC5		92.2		150	
SPS transformer TC1 coil		86.6		110	
Inductor LB6		84.3		110	
Film capacitor CB50		83.3		105	
Output CT HCTB1		82.9		85	
Output Relay RY3B		83.0		85	
Inductor LB1		89.6		110	
MOVB2		83.1		85	
X capacitor CB3		81.8		110	
CYB5A Y Cap		80.5		110	
Output wire		87.3		105	
Inductor LB2		86.7		110	
AC Connector		80.4		85	
Outside fan		69.2		85	
Display		78.4		85	
Heatsink / mounting surface		66.8		100	
TABLE: Heating test, resistance method					
	Test voltage (V).....				—
	Ambient, t₁(°C).....				—
	Ambient, t₂(°C).....				—
Temperature rise of winding	R₁(Ω)	R₂(Ω)	ΔT (K)	Max. dT (K)	Insulation class

Supplementary information:

4.4		TABLE: fault condition tests					P
		ambient temperature (°C): 25.4°C					—
No.	component No.	fault	test voltage (V)	test time	fuse No.	fuse current (A)	result
1	PCE input	Reversed	DC 640/800	30min	--	--	DC Input: 0V /0A /0W AC Output: 230V /0A /0W FID: Inverter can't start MT: n.a. SD: <input checked="" type="checkbox"/> Yes / <input type="checkbox"/> No, GD: <input checked="" type="checkbox"/> Yes / <input type="checkbox"/> No RO: <input checked="" type="checkbox"/> Yes / <input type="checkbox"/> No, NCD: <input checked="" type="checkbox"/> Yes / <input type="checkbox"/> No NH: <input checked="" type="checkbox"/> Pass / <input type="checkbox"/> Fail. DST: <input checked="" type="checkbox"/> Pass / <input type="checkbox"/> Fail.
2	PCE input	s-c	DC 640/800	30min	--	--	DC Input: 0V /0A /0W AC Output: 230V /0A /0W FID: Inverter can't start MT: n.a. SD: <input checked="" type="checkbox"/> Yes / <input type="checkbox"/> No, GD: <input checked="" type="checkbox"/> Yes / <input type="checkbox"/> No RO: <input checked="" type="checkbox"/> Yes / <input type="checkbox"/> No, NCD: <input checked="" type="checkbox"/> Yes / <input type="checkbox"/> No NH: <input checked="" type="checkbox"/> Pass / <input type="checkbox"/> Fail. DST: <input checked="" type="checkbox"/> Pass / <input type="checkbox"/> Fail.
3	PCE input	Over-voltage	DC 980	30min	--	--	DC Input: 980V /0A /0W AC Output: 230V /0A /0W FID: Inverter shutdown immediately and LCD display "BusOVP" and "Pvovp" fault. MT: n.a. SD: <input checked="" type="checkbox"/> Yes / <input type="checkbox"/> No, GD: <input checked="" type="checkbox"/> Yes / <input type="checkbox"/> No RO: <input checked="" type="checkbox"/> Yes / <input type="checkbox"/> No, NCD: <input checked="" type="checkbox"/> Yes / <input type="checkbox"/> No NH: <input checked="" type="checkbox"/> Pass / <input type="checkbox"/> Fail. DST: <input checked="" type="checkbox"/> Pass / <input type="checkbox"/> Fail.
4	PCE input (only for multistring)	Different input MPP1: low input MPP2: high input	DC 480/800	30min	--	--	DC Input: MPPT1: 800V/23.7A/18960W MPPT2: 480V/42.1A/20208W MPPT3: 480V/47.4A/22752W AC Output: 230V/266A/60.3kW FID: Inverter work normally. MT: n.a. SD: <input type="checkbox"/> Yes / <input checked="" type="checkbox"/> No, GD: <input type="checkbox"/> Yes / <input checked="" type="checkbox"/> No RO: <input type="checkbox"/> Yes / <input type="checkbox"/> No, NCD: <input checked="" type="checkbox"/> Yes / <input type="checkbox"/> No NH: <input checked="" type="checkbox"/> Pass / <input type="checkbox"/> Fail. DST: <input checked="" type="checkbox"/> Pass / <input type="checkbox"/> Fail.
5	PCE input (only for multistring)	Same input (MPP1 & MPP2 from same power source)	DC 640/800	30min	--	--	DC Input: 640V/93.9A/60100W AC Output: 230V/254A/58399W FID: Inverter work normally. MT: n.a. SD: <input type="checkbox"/> Yes / <input checked="" type="checkbox"/> No, GD: <input type="checkbox"/> Yes / <input checked="" type="checkbox"/> No RO: <input type="checkbox"/> Yes / <input type="checkbox"/> No, NCD: <input checked="" type="checkbox"/> Yes / <input type="checkbox"/> No NH: <input checked="" type="checkbox"/> Pass / <input type="checkbox"/> Fail. DST: <input checked="" type="checkbox"/> Pass / <input type="checkbox"/> Fail.
6	PCE output	Power over-feed (OCP & OTP function controlled by DSP / software is disable)	DC 640/800	30min	--	--	DC Input: 800V /0A /0W AC Output: 230V /0A /0W FID: Inverter shutdown, LCD display "HwAcOCP" fault. MT: n.a. SD: <input checked="" type="checkbox"/> Yes / <input type="checkbox"/> No, GD: <input checked="" type="checkbox"/> Yes / <input type="checkbox"/> No RO: <input checked="" type="checkbox"/> Yes / <input type="checkbox"/> No, NCD: <input checked="" type="checkbox"/> Yes / <input type="checkbox"/> No NH: <input checked="" type="checkbox"/> Pass / <input type="checkbox"/> Fail. DST: <input checked="" type="checkbox"/> Pass / <input type="checkbox"/> Fail.

7	PCE output	Over-voltage (OVP function controlled by DSP / software is disable)	DC 640/800	30min	--	--	DC Input: 800V /0A/0W AC Output: 230V /0A/0W FID: Inverter shut down, LCD display "Grid OVP" fault. MT: n.a. SD: <input checked="" type="checkbox"/> Yes / <input type="checkbox"/> No, GD: <input checked="" type="checkbox"/> Yes / <input type="checkbox"/> No RO: <input checked="" type="checkbox"/> Yes / <input type="checkbox"/> No, NCD: <input checked="" type="checkbox"/> Yes / <input type="checkbox"/> No NH: <input checked="" type="checkbox"/> Pass / <input type="checkbox"/> Fail. DST: <input checked="" type="checkbox"/> Pass / <input type="checkbox"/> Fail.
8	PCE output	s-c	DC 640/800	30min	--	--	DC Input: 800V /0A/0W AC Output: 230V /0A/0W FID: Inverter shutdown immediately, LCD displays "HwAcOCP"fault. MT: n.a. SD: <input checked="" type="checkbox"/> Yes / <input type="checkbox"/> No, GD: <input checked="" type="checkbox"/> Yes / <input type="checkbox"/> No RO: <input checked="" type="checkbox"/> Yes / <input type="checkbox"/> No, NCD: <input checked="" type="checkbox"/> Yes / <input type="checkbox"/> No NH: <input checked="" type="checkbox"/> Pass / <input type="checkbox"/> Fail. DST: <input checked="" type="checkbox"/> Pass / <input type="checkbox"/> Fail.
9	PCE output	Phase sequence or polarity incorrect	DC 640/800	30min	--	--	DC Input: 640V/93.9A/60100W AC Output: 230V/254A/58399W FID: Inverter work normally. MT: n.a. SD: <input type="checkbox"/> Yes / <input checked="" type="checkbox"/> No, GD: <input type="checkbox"/> Yes / <input checked="" type="checkbox"/> No RO: <input type="checkbox"/> Yes / <input type="checkbox"/> No, NCD: <input checked="" type="checkbox"/> Yes / <input type="checkbox"/> No NH: <input checked="" type="checkbox"/> Pass / <input type="checkbox"/> Fail. DST: <input checked="" type="checkbox"/> Pass / <input type="checkbox"/> Fail.
10	PCE output	A-Phase miswiring grid connection	DC 640/800	30min	--	--	DC Input: 800V /0A/0W AC Output: 230V /0A/0W FID: Inverter shut down, LCD display "Grid UVP" fault. MT: n.a. SD: <input checked="" type="checkbox"/> Yes / <input type="checkbox"/> No, GD: <input checked="" type="checkbox"/> Yes / <input type="checkbox"/> No RO: <input checked="" type="checkbox"/> Yes / <input type="checkbox"/> No, NCD: <input checked="" type="checkbox"/> Yes / <input type="checkbox"/> No NH: <input checked="" type="checkbox"/> Pass / <input type="checkbox"/> Fail. DST: <input checked="" type="checkbox"/> Pass / <input type="checkbox"/> Fail.
11	PCE output	B-Phase miswiring grid connection	DC 640/800	30min	--	--	DC Input: 800V /0A/0W AC Output: 230V /0A/0W FID: Inverter shut down, LCD display "Grid UVP" fault. MT: n.a. SD: <input checked="" type="checkbox"/> Yes / <input type="checkbox"/> No, GD: <input checked="" type="checkbox"/> Yes / <input type="checkbox"/> No RO: <input checked="" type="checkbox"/> Yes / <input type="checkbox"/> No, NCD: <input checked="" type="checkbox"/> Yes / <input type="checkbox"/> No NH: <input checked="" type="checkbox"/> Pass / <input type="checkbox"/> Fail. DST: <input checked="" type="checkbox"/> Pass / <input type="checkbox"/> Fail.
12	PCE output	C-Phase miswiring grid connection	DC 640/800	30min	--	--	DC Input: 800V /0A/0W AC Output: 230V /0A/0W FID: Inverter shut down, LCD display "Grid UVP" fault. MT: n.a. SD: <input checked="" type="checkbox"/> Yes / <input type="checkbox"/> No, GD: <input checked="" type="checkbox"/> Yes / <input type="checkbox"/> No RO: <input checked="" type="checkbox"/> Yes / <input type="checkbox"/> No, NCD: <input checked="" type="checkbox"/> Yes / <input type="checkbox"/> No NH: <input checked="" type="checkbox"/> Pass / <input type="checkbox"/> Fail. DST: <input checked="" type="checkbox"/> Pass / <input type="checkbox"/> Fail.
13	PCE Cooling system failure	Fan locked	DC 640/800	3h	--	--	DC Input: 640V/93.9A/60100W AC Output: 230V/254A/58399W FID: Inverter work normally. LCD display "Fan alarm" fault. MT: n.a. SD: <input type="checkbox"/> Yes / <input checked="" type="checkbox"/> No, GD: <input type="checkbox"/> Yes / <input checked="" type="checkbox"/> No RO: <input type="checkbox"/> Yes / <input type="checkbox"/> No, NCD: <input checked="" type="checkbox"/> Yes / <input type="checkbox"/> No NH: <input checked="" type="checkbox"/> Pass / <input type="checkbox"/> Fail. DST: <input checked="" type="checkbox"/> Pass / <input type="checkbox"/> Fail.

14	PCE Cooling system failure	Opening blocked	DC 640/800	3h	--	--	DC Input: 640V/93.9A/60100W AC Output: 230V/254A/58399W FID: Inverter work normally. MT: n.a SD: <input type="checkbox"/> Yes / <input checked="" type="checkbox"/> No, GD: <input type="checkbox"/> Yes / <input checked="" type="checkbox"/> No RO: <input type="checkbox"/> Yes / <input type="checkbox"/> No, NCD: <input checked="" type="checkbox"/> Yes / <input type="checkbox"/> No NH: <input checked="" type="checkbox"/> Pass / <input type="checkbox"/> Fail. DST: <input checked="" type="checkbox"/> Pass / <input type="checkbox"/> Fail.
15	PCE Cooling system failure	Blanketing test	DC 640/800	3h	--	--	DC Input: 640V/93.9A/60100W AC Output: 230V/254A/58399W FID: Inverter work normally. MT: Enclosure: 79.5°C, Ambient: 29°C SD: <input type="checkbox"/> Yes / <input checked="" type="checkbox"/> No, GD: <input type="checkbox"/> Yes / <input checked="" type="checkbox"/> No RO: <input type="checkbox"/> Yes / <input type="checkbox"/> No, NCD: <input checked="" type="checkbox"/> Yes / <input type="checkbox"/> No NH: <input checked="" type="checkbox"/> Pass / <input type="checkbox"/> Fail. DST: <input checked="" type="checkbox"/> Pass / <input type="checkbox"/> Fail.
MCU or DPS processer failure							
16	DSP failure	+1.9V power supply disable (ECC12 s-c)	DC 640/800	30min	--	--	DC Input: 800V /0A/0W AC Output: 230V /0A/0W FID: Inverter shut down immediately. No display. MT: n.a. SD: <input checked="" type="checkbox"/> Yes / <input type="checkbox"/> No, GD: <input checked="" type="checkbox"/> Yes / <input type="checkbox"/> No RO: <input checked="" type="checkbox"/> Yes / <input type="checkbox"/> No, NCD: <input checked="" type="checkbox"/> Yes / <input type="checkbox"/> No NH: <input checked="" type="checkbox"/> Pass / <input type="checkbox"/> Fail. DST: <input checked="" type="checkbox"/> Pass / <input type="checkbox"/> Fail.
17	DSP failure	+3.3V power supply disable (UC13 Pin 2 s-c)	DC 640/800	30min	--	--	DC Input: 800V /0A/0W AC Output: 230V /0A/0W FID: Inverter shut down immediately. LCD display "SCI Comm lose". MT: n.a. SD: <input checked="" type="checkbox"/> Yes / <input type="checkbox"/> No, GD: <input checked="" type="checkbox"/> Yes / <input type="checkbox"/> No RO: <input checked="" type="checkbox"/> Yes / <input type="checkbox"/> No, NCD: <input checked="" type="checkbox"/> Yes / <input type="checkbox"/> No NH: <input checked="" type="checkbox"/> Pass / <input type="checkbox"/> Fail. DST: <input checked="" type="checkbox"/> Pass / <input type="checkbox"/> Fail.
18	DSP failure	+5V power supply disable (LC20 Pin 1 to GND s-c)	DC 640/800	30min	--	--	DC Input: 800V /0A/0W AC Output: 230V /0A/0W FID: Inverter shut down immediately. LCD display "SCI Comm lose". MT: n.a. SD: <input checked="" type="checkbox"/> Yes / <input type="checkbox"/> No, GD: <input checked="" type="checkbox"/> Yes / <input type="checkbox"/> No RO: <input checked="" type="checkbox"/> Yes / <input type="checkbox"/> No, NCD: <input checked="" type="checkbox"/> Yes / <input type="checkbox"/> No NH: <input checked="" type="checkbox"/> Pass / <input type="checkbox"/> Fail. DST: <input checked="" type="checkbox"/> Pass / <input type="checkbox"/> Fail.
19	DSP failure	reset	DC 640/800	30min	--	--	DC Input: 800V /0A/0W AC Output: 230V /0A/0W FID: Inverter shut down immediately. LCD display "SCI Comm lose". MT: n.a. SD: <input checked="" type="checkbox"/> Yes / <input type="checkbox"/> No, GD: <input checked="" type="checkbox"/> Yes / <input type="checkbox"/> No RO: <input checked="" type="checkbox"/> Yes / <input type="checkbox"/> No, NCD: <input checked="" type="checkbox"/> Yes / <input type="checkbox"/> No NH: <input checked="" type="checkbox"/> Pass / <input type="checkbox"/> Fail. DST: <input checked="" type="checkbox"/> Pass / <input type="checkbox"/> Fail.
20	DSP failure	Redundancy protect	DC 640/800	30min	--	--	DC Input: 800V /0A/0W AC Output: 230V /0A/0W FID: Inverter shut down immediately. LCD display "Mchip-Fault". MT: n.a. SD: <input checked="" type="checkbox"/> Yes / <input type="checkbox"/> No, GD: <input checked="" type="checkbox"/> Yes / <input type="checkbox"/> No RO: <input checked="" type="checkbox"/> Yes / <input type="checkbox"/> No, NCD: <input checked="" type="checkbox"/> Yes / <input type="checkbox"/> No NH: <input checked="" type="checkbox"/> Pass / <input type="checkbox"/> Fail. DST: <input checked="" type="checkbox"/> Pass / <input type="checkbox"/> Fail.
Loss of control & Function check fault							

21	IGBT PMW	Loss / failure (no power)	DC 640/800	30min	--	--	DC Input: 800V /0A/0W AC Output: 230V /0A /0W FID: Inverter shut down. LCD shows "DCI OCP" fault. MT: n.a. SD: <input checked="" type="checkbox"/> Yes/ <input type="checkbox"/> No, GD: <input checked="" type="checkbox"/> Yes/ <input type="checkbox"/> No RO: <input checked="" type="checkbox"/> Yes/ <input type="checkbox"/> No, NCD: <input checked="" type="checkbox"/> Yes/ <input type="checkbox"/> No NH: <input checked="" type="checkbox"/> Pass/ <input type="checkbox"/> Fail. DST: <input checked="" type="checkbox"/> Pass/ <input type="checkbox"/> Fail.
22	IGBT PMW	Loss / failure (one bridge on always)	DC 640/800	30min	--	--	DC Input: 800V /0A/0W AC Output: 230V /0A /0W FID: Inverter shut down. IGBTD1, IGBTD2, IGBTD3, RY1, RY2 damaged. MT: n.a. SD: <input checked="" type="checkbox"/> Yes/ <input type="checkbox"/> No, GD: <input checked="" type="checkbox"/> Yes/ <input type="checkbox"/> No RO: <input type="checkbox"/> Yes/ <input checked="" type="checkbox"/> No, NCD: <input type="checkbox"/> Yes/ <input checked="" type="checkbox"/> No NH: <input checked="" type="checkbox"/> Pass/ <input type="checkbox"/> Fail. DST: <input checked="" type="checkbox"/> Pass/ <input type="checkbox"/> Fail.
23	IGBT PMW	Loss / failure (No driver)	DC 640/800	30min	--	--	DC Input: 800V /0A/0W AC Output: 230V /0A /0W FID: Inverter shut down. LCD shows "Vbus Unbalance" fault. MT: n.a. SD: <input checked="" type="checkbox"/> Yes/ <input type="checkbox"/> No, GD: <input checked="" type="checkbox"/> Yes/ <input type="checkbox"/> No RO: <input checked="" type="checkbox"/> Yes/ <input type="checkbox"/> No, NCD: <input checked="" type="checkbox"/> Yes/ <input type="checkbox"/> No NH: <input checked="" type="checkbox"/> Pass/ <input type="checkbox"/> Fail. DST: <input checked="" type="checkbox"/> Pass/ <input type="checkbox"/> Fail.
24	PV/DC Voltage detector (RA9 s-c)	Loss / failure	DC 640/800	30min	--	--	DC Input: 800V /0A/0W AC Output: 230V /0A /0W FID: Inverter shut down. LCD shows "PV OVP" fault. MT: n.a. SD: <input checked="" type="checkbox"/> Yes/ <input type="checkbox"/> No, GD: <input checked="" type="checkbox"/> Yes/ <input type="checkbox"/> No RO: <input checked="" type="checkbox"/> Yes/ <input type="checkbox"/> No, NCD: <input checked="" type="checkbox"/> Yes/ <input type="checkbox"/> No NH: <input checked="" type="checkbox"/> Pass/ <input type="checkbox"/> Fail. DST: <input checked="" type="checkbox"/> Pass/ <input type="checkbox"/> Fail.
25	PV/DC current detector (UC624 7 PIN o-c)	Loss / failure	DC 640/800	30min	--	--	DC Input: 800V /0A/0W AC Output: 230V /0A /0W FID: Inverter shut down. LCD shows "Hw Boost OCP" fault. MT: n.a. SD: <input checked="" type="checkbox"/> Yes/ <input type="checkbox"/> No, GD: <input checked="" type="checkbox"/> Yes/ <input type="checkbox"/> No RO: <input checked="" type="checkbox"/> Yes/ <input type="checkbox"/> No, NCD: <input checked="" type="checkbox"/> Yes/ <input type="checkbox"/> No NH: <input checked="" type="checkbox"/> Pass/ <input type="checkbox"/> Fail. DST: <input checked="" type="checkbox"/> Pass/ <input type="checkbox"/> Fail.
26	BUS Voltage detector RC126 s-c	Loss / failure	DC 640/800	30min	--	--	DC Input: 640V /0A/0W AC Output: 230V /0A /0W FID: Inverter shutdown immediately. LCD shows "BusVdtZeroFault" fault. MT: n.a. SD: <input checked="" type="checkbox"/> Yes/ <input type="checkbox"/> No, GD: <input checked="" type="checkbox"/> Yes/ <input type="checkbox"/> No RO: <input checked="" type="checkbox"/> Yes/ <input type="checkbox"/> No, NCD: <input checked="" type="checkbox"/> Yes/ <input type="checkbox"/> No NH: <input checked="" type="checkbox"/> Pass/ <input type="checkbox"/> Fail. DST: <input checked="" type="checkbox"/> Pass/ <input type="checkbox"/> Fail.
27	Inverter current detector (RC37 s-c)	Loss / failure	DC 640/800	30min	--	--	DC Input: 640V /0A/0W AC Output: 230V /0A /0W FID: Inverter shutdown immediately. LCD shows "BusVdtZeroFault" fault. MT: n.a. SD: <input checked="" type="checkbox"/> Yes/ <input type="checkbox"/> No, GD: <input checked="" type="checkbox"/> Yes/ <input type="checkbox"/> No RO: <input checked="" type="checkbox"/> Yes/ <input type="checkbox"/> No, NCD: <input checked="" type="checkbox"/> Yes/ <input type="checkbox"/> No NH: <input checked="" type="checkbox"/> Pass/ <input type="checkbox"/> Fail. DST: <input checked="" type="checkbox"/> Pass/ <input type="checkbox"/> Fail.

28	Grid/AC voltage detector (UC627 s-c)	Loss / failure	DC 640/800	30min	--	--	DC Input: 640V /0A/0W AC Output: 230V /0A/0W FID: Inverter shut down. LCD shows "Grid UVP" fault. MT: n.a. SD: <input checked="" type="checkbox"/> Yes/ <input type="checkbox"/> No, GD: <input checked="" type="checkbox"/> Yes/ <input type="checkbox"/> No RO: <input checked="" type="checkbox"/> Yes/ <input type="checkbox"/> No, NCD: <input checked="" type="checkbox"/> Yes/ <input type="checkbox"/> No NH: <input checked="" type="checkbox"/> Pass/ <input type="checkbox"/> Fail. DST: <input checked="" type="checkbox"/> Pass/ <input type="checkbox"/> Fail.
29	DC isolation device function check	Loss / failure	DC 640/800	30min	--	--	DC Input: 800V /0A/0W AC Output: 230V /0A/0W FID: Inverter shut down. No display. MT: n.a. SD: <input checked="" type="checkbox"/> Yes/ <input type="checkbox"/> No, GD: <input checked="" type="checkbox"/> Yes/ <input type="checkbox"/> No RO: <input checked="" type="checkbox"/> Yes/ <input type="checkbox"/> No, NCD: <input checked="" type="checkbox"/> Yes/ <input type="checkbox"/> No NH: <input checked="" type="checkbox"/> Pass/ <input type="checkbox"/> Fail. DST: <input checked="" type="checkbox"/> Pass/ <input type="checkbox"/> Fail.
30	Relay function check K1 o-c	Loss / failure	DC 640/800	30min	--	--	DC Input: 640V /0A/0W AC Output: 230V /0A/0W FID: Inverter shut down. LCD display "Vbus Unbalance". MT: n.a. SD: <input checked="" type="checkbox"/> Yes/ <input type="checkbox"/> No, GD: <input checked="" type="checkbox"/> Yes/ <input type="checkbox"/> No RO: <input checked="" type="checkbox"/> Yes/ <input type="checkbox"/> No, NCD: <input checked="" type="checkbox"/> Yes/ <input type="checkbox"/> No NH: <input checked="" type="checkbox"/> Pass/ <input type="checkbox"/> Fail. DST: <input checked="" type="checkbox"/> Pass/ <input type="checkbox"/> Fail.
31	Relay function check K2 o-c	Loss / failure	DC 640/800	30min	--	--	DC Input: 640V /0A/0W AC Output: 230V /0A/0W FID: Inverter shut down. LCD display "Vbus Unbalance". MT: n.a. SD: <input checked="" type="checkbox"/> Yes/ <input type="checkbox"/> No, GD: <input checked="" type="checkbox"/> Yes/ <input type="checkbox"/> No RO: <input checked="" type="checkbox"/> Yes/ <input type="checkbox"/> No, NCD: <input checked="" type="checkbox"/> Yes/ <input type="checkbox"/> No NH: <input checked="" type="checkbox"/> Pass/ <input type="checkbox"/> Fail. DST: <input checked="" type="checkbox"/> Pass/ <input type="checkbox"/> Fail.
32	Relay function check K3 o-c	Loss / failure	DC 640/800	30min	--	--	DC Input: 640V /0A/0W AC Output: 230V /0A/0W FID: Inverter shut down. LCD display "Vbus Unbalance". MT: n.a. SD: <input checked="" type="checkbox"/> Yes/ <input type="checkbox"/> No, GD: <input checked="" type="checkbox"/> Yes/ <input type="checkbox"/> No RO: <input checked="" type="checkbox"/> Yes/ <input type="checkbox"/> No, NCD: <input checked="" type="checkbox"/> Yes/ <input type="checkbox"/> No NH: <input checked="" type="checkbox"/> Pass/ <input type="checkbox"/> Fail. DST: <input checked="" type="checkbox"/> Pass/ <input type="checkbox"/> Fail.
33	Ambient temperature detector RC456 s-c	Loss / failure	DC 640/800	30min	--	--	DC Input: 580V /0A/0W AC Output: 230V /0A/0W FID: Inverter shut down. LCD display "Over Temp Derating" fault. MT: n.a. SD: <input checked="" type="checkbox"/> Yes/ <input type="checkbox"/> No, GD: <input checked="" type="checkbox"/> Yes/ <input type="checkbox"/> No RO: <input checked="" type="checkbox"/> Yes/ <input type="checkbox"/> No, NCD: <input checked="" type="checkbox"/> Yes/ <input type="checkbox"/> No NH: <input checked="" type="checkbox"/> Pass/ <input type="checkbox"/> Fail. DST: <input checked="" type="checkbox"/> Pass/ <input type="checkbox"/> Fail.
34	Ambient temperature detector RC190 o-c	Loss / failure	DC 640/800	30min	--	--	DC Input: 640V /19.75A/12641W AC Output: 230V /53.48A/12300W FID: Work normally. MT: n.a. SD: <input checked="" type="checkbox"/> Yes/ <input type="checkbox"/> No, GD: <input checked="" type="checkbox"/> Yes/ <input type="checkbox"/> No RO: <input checked="" type="checkbox"/> Yes/ <input type="checkbox"/> No, NCD: <input checked="" type="checkbox"/> Yes/ <input type="checkbox"/> No NH: <input checked="" type="checkbox"/> Pass/ <input type="checkbox"/> Fail. DST: <input checked="" type="checkbox"/> Pass/ <input type="checkbox"/> Fail.

35	IGBT temperature detector UC621 s-c	Loss / failure	DC 640/800	30min	--	--	DC Input: 640V /0A /0W AC Output: 230V /0A /0W FID: Inverter shut down. LCD display "Over Temp Derating" fault. MT: n.a. SD: <input checked="" type="checkbox"/> Yes / <input type="checkbox"/> No, GD: <input checked="" type="checkbox"/> Yes / <input type="checkbox"/> No RO: <input checked="" type="checkbox"/> Yes / <input type="checkbox"/> No, NCD: <input checked="" type="checkbox"/> Yes / <input type="checkbox"/> No NH: <input checked="" type="checkbox"/> Pass / <input type="checkbox"/> Fail. DST: <input checked="" type="checkbox"/> Pass / <input type="checkbox"/> Fail.
36	IGBT temperature detector RC487 o-c	Loss / failure	DC 640/800	30min	--	--	DC Input: 640V /2.4A /1390W AC Output: 230V /5.8A /1320W FID: Work normally. MT: n.a. SD: <input checked="" type="checkbox"/> Yes / <input type="checkbox"/> No, GD: <input checked="" type="checkbox"/> Yes / <input type="checkbox"/> No RO: <input checked="" type="checkbox"/> Yes / <input type="checkbox"/> No, NCD: <input checked="" type="checkbox"/> Yes / <input type="checkbox"/> No NH: <input checked="" type="checkbox"/> Pass / <input type="checkbox"/> Fail. DST: <input checked="" type="checkbox"/> Pass / <input type="checkbox"/> Fail.
37	Heatsink temperature detector RC454 s-c	Loss / failure	DC 640/800	30min	--	--	DC Input: 640V /0A /0W AC Output: 230V /0A /0W FID: Inverter shut down. LCD display "Over Temp Derating" fault. MT: n.a. SD: <input checked="" type="checkbox"/> Yes / <input type="checkbox"/> No, GD: <input checked="" type="checkbox"/> Yes / <input type="checkbox"/> No RO: <input checked="" type="checkbox"/> Yes / <input type="checkbox"/> No, NCD: <input checked="" type="checkbox"/> Yes / <input type="checkbox"/> No NH: <input checked="" type="checkbox"/> Pass / <input type="checkbox"/> Fail. DST: <input checked="" type="checkbox"/> Pass / <input type="checkbox"/> Fail.
38	Heatsink temperature detector RC447 o-c	Loss / failure	DC 640/800	30min	--	--	DC Input: 640V /19.75A /12641W AC Output: 230V /53.48A /12300W FID: Work normally. MT: n.a. SD: <input checked="" type="checkbox"/> Yes / <input type="checkbox"/> No, GD: <input checked="" type="checkbox"/> Yes / <input type="checkbox"/> No RO: <input checked="" type="checkbox"/> Yes / <input type="checkbox"/> No, NCD: <input checked="" type="checkbox"/> Yes / <input type="checkbox"/> No NH: <input checked="" type="checkbox"/> Pass / <input type="checkbox"/> Fail. DST: <input checked="" type="checkbox"/> Pass / <input type="checkbox"/> Fail.

Components single fault condition and Functional insulation on PWB short circuit test

39	IGBT (IGBT D-S)	s-c	DC 640/800	30min	--	--	DC Input: 800V /0A /0W AC Output: 230V /0A /0W FID: Inverter shut down. IGBTD1, IGBTD2, IGBTD3, RY1, RY2 damaged. MT: n.a. SD: <input checked="" type="checkbox"/> Yes / <input type="checkbox"/> No, GD: <input checked="" type="checkbox"/> Yes / <input type="checkbox"/> No RO: <input type="checkbox"/> Yes / <input checked="" type="checkbox"/> No, NCD: <input type="checkbox"/> Yes / <input checked="" type="checkbox"/> No NH: <input checked="" type="checkbox"/> Pass / <input type="checkbox"/> Fail. DST: <input checked="" type="checkbox"/> Pass / <input type="checkbox"/> Fail.
40	DC input Bus capacitor	s-c	DC 640/800	30min	--	--	DC Input: 800V /0A /0W AC Output: 230V /0A /0W FID: Inverter shut down. IGBTD1, IGBTD2, IGBTD3, RY1, RY2 damaged. MT: n.a. SD: <input checked="" type="checkbox"/> Yes / <input type="checkbox"/> No, GD: <input checked="" type="checkbox"/> Yes / <input type="checkbox"/> No RO: <input type="checkbox"/> Yes / <input checked="" type="checkbox"/> No, NCD: <input type="checkbox"/> Yes / <input checked="" type="checkbox"/> No NH: <input checked="" type="checkbox"/> Pass / <input type="checkbox"/> Fail. DST: <input checked="" type="checkbox"/> Pass / <input type="checkbox"/> Fail.
41	DC input filter capacitor	s-c	DC 640/800	30min	--	--	DC Input: 580V /0A /0W AC Output: 230V /0A /0W FID: Inverter shutdown immediately. No display. MT: n.a. SD: <input checked="" type="checkbox"/> Yes / <input type="checkbox"/> No, GD: <input checked="" type="checkbox"/> Yes / <input type="checkbox"/> No RO: <input checked="" type="checkbox"/> Yes / <input type="checkbox"/> No, NCD: <input checked="" type="checkbox"/> Yes / <input type="checkbox"/> No NH: <input checked="" type="checkbox"/> Pass / <input type="checkbox"/> Fail. DST: <input checked="" type="checkbox"/> Pass / <input type="checkbox"/> Fail.

42	LC filter capacitor	s-c	DC 640/800	30min	--	--	DC Input: 640V /0A /0W AC Output: 230V /0A /0W FID: Inverter shutdown immediately. RY1, RY2 damaged. MT: n.a. SD: <input checked="" type="checkbox"/> Yes / <input type="checkbox"/> No, GD: <input checked="" type="checkbox"/> Yes / <input type="checkbox"/> No RO: <input type="checkbox"/> Yes / <input checked="" type="checkbox"/> No, NCD: <input type="checkbox"/> Yes / <input checked="" type="checkbox"/> No NH: <input checked="" type="checkbox"/> Pass / <input type="checkbox"/> Fail. DST: <input checked="" type="checkbox"/> Pass / <input type="checkbox"/> Fail.
43	Power supply transformer TC1	Output 12.5 V s-c	DC 640/800	30min	--	--	DC Input: 640V /0A /0W AC Output: 230V /0A /0W FID: Inverter shutdown immediately. LCD display abnormal. MT: n.a. SD: <input checked="" type="checkbox"/> Yes / <input type="checkbox"/> No, GD: <input checked="" type="checkbox"/> Yes / <input type="checkbox"/> No RO: <input checked="" type="checkbox"/> Yes / <input type="checkbox"/> No, NCD: <input checked="" type="checkbox"/> Yes / <input type="checkbox"/> No NH: <input checked="" type="checkbox"/> Pass / <input type="checkbox"/> Fail. DST: <input checked="" type="checkbox"/> Pass / <input type="checkbox"/> Fail.
44	Power supply transformer TC1	Output 9 V s-c	DC 640/800	30min	--	--	DC Input: 640V /0A /0W AC Output: 230V /0A /0W FID: Inverter shutdown immediately. Inverter keep reset status. MT: n.a. SD: <input checked="" type="checkbox"/> Yes / <input type="checkbox"/> No, GD: <input checked="" type="checkbox"/> Yes / <input type="checkbox"/> No RO: <input checked="" type="checkbox"/> Yes / <input type="checkbox"/> No, NCD: <input checked="" type="checkbox"/> Yes / <input type="checkbox"/> No NH: <input checked="" type="checkbox"/> Pass / <input type="checkbox"/> Fail. DST: <input checked="" type="checkbox"/> Pass / <input type="checkbox"/> Fail.
45	Power supply transformer TC1	Output 12 V s-c	DC 640/800	30min	--	--	DC Input: 640V /0A /0W AC Output: 230V /0A /0W FID: Inverter shutdown immediately. Inverter keep reset status. MT: n.a. SD: <input checked="" type="checkbox"/> Yes / <input type="checkbox"/> No, GD: <input checked="" type="checkbox"/> Yes / <input type="checkbox"/> No RO: <input checked="" type="checkbox"/> Yes / <input type="checkbox"/> No, NCD: <input checked="" type="checkbox"/> Yes / <input type="checkbox"/> No NH: <input checked="" type="checkbox"/> Pass / <input type="checkbox"/> Fail. DST: <input checked="" type="checkbox"/> Pass / <input type="checkbox"/> Fail.
46	Power supply transformer TC1	Output 12 V s-c	DC 640/800	30min	--	--	DC Input: 640V /0A /0W AC Output: 230V /0A /0W FID: Inverter shutdown immediately. Inverter keep reset status. MT: n.a. SD: <input checked="" type="checkbox"/> Yes / <input type="checkbox"/> No, GD: <input checked="" type="checkbox"/> Yes / <input type="checkbox"/> No RO: <input checked="" type="checkbox"/> Yes / <input type="checkbox"/> No, NCD: <input checked="" type="checkbox"/> Yes / <input type="checkbox"/> No NH: <input checked="" type="checkbox"/> Pass / <input type="checkbox"/> Fail. DST: <input checked="" type="checkbox"/> Pass / <input type="checkbox"/> Fail.

supplementary information

FID	Fault Indication	MT	Max. Temperature
SD	PCE Shut Down:	DG	Disconnection To Grid
RO	Recovered to Operate after removing the single fault setting	NCD	No comp. or parts damaged
NH	No hazards occurred	DST	Dielectric strength test
s-c	short-circuited	o-c	open-circuited
o-l	Over-load.		

Note(s):

Failures or faults may be short-circuits in the PCE, or to exposed conductive parts, earth faults, or short-circuit in

the output circuits, failure in the control circuits, or blocking of a motor fed by power EE.

There shall be no emission of molten metal, burning insulation, or flaming or glowing particles FIDom the fire

enclosure, and there shall be no charring, glowing, or flaming of the tissue paper or cheesecloth, or glowing or

flaming of surgical cotton.

Faults protected by "UL certified current fuse only" shall be performed and repeated 3 times.

In case of components damaged other than fuse, the evaluation should be repeated 3 times.

Report in result section:

- Measure transformer temperature at all times

- Fuse opened Yes / No?

- Components damaged?

- Emit Flames?

- Emit molten metal?

- Did it pass the electric strength test?

What happened to the SPS? Shutdown / cycle protection / normal operation

See technical documentation.

7.3.6.3.3 TABLE: protective equipotential bonding ;					P
Measured between:	Test current (A)	Voltage drop (V)	Resistance (mΩ)	result	
Earthing terminal and Enclosure	60	0.12	2	Pass	
supplementary information: N/A					

7.3.7 TABLE: clearance and creepage distance measurements							P
clearance cl and creepage distance dcr at / of:	Up (V)	U r.m.s. (V)	required cl (mm)	cl (mm)	required dcr (mm)	dcr (mm)	
PCE unit (Vmax PV: OVCII 1000Vdc, OVC III 277Vac, 50Hz)							
PV supply circuits line to line: FI	1000 Vdc	277 Vac	3.6	>20	10	>20	
PV supply circuits / AC mains circuit to metal chassis: BI	1000 Vdc	277 Vac	3.6	See below	10	See below	
-at IGBT	1000 Vdc	277 Vac	3.6	12	10	>12	
-at PCB	1000 Vdc	277 Vac	3.6	12	10	>12	

7.3.7	TABLE: clearance and creepage distance measurements						P
AC mains circuit L1 to L2 to L3: FI	1000 Vdc	277 Vac	3.6	15	10	15	
AC mains circuit L to N: FI	1000 Vdc	277 Vac	3.6	15	10	15	
PV Input Board (150-303001-2 V03)							
PV supply terminal “ + “ to “ - “ : FI	1000 Vdc	277 Vac	3.6	5.3	5	5.3	
PV supply circuits to earth: BI	1000 Vdc	277 Vac	3.6	See below	5	See below	
-at RA25-RA30	1000 Vdc	277 Vac	3.6	12	5	12	
-at Trace	1000 Vdc	277 Vac	3.6	5.3	5	5.3	
PV supply circuits to Control circuits: BI	1000 Vdc	277 Vac	3.6	See below	5	See below	
-at Trace	1000 Vdc	277 Vac	3.6	5.6	5	5.6	
-at RA8-RA12, RA39,RA38,RA62	1000 Vdc	277 Vac	3.6	12	5	12	
-at HCTA1, HCTA2	1000 Vdc	277 Vac	3.6	5.6	5	5.6	
AC Output Board (019.00040004-1 V10)							
AC mains circuit L1 to L2 to L3): FI	1000 Vdc	277 Vac	3.6	5.2	5	5.2	
AC mains circuit L to N: FI	1000 Vdc	277 Vac	3.6	5.2	5	5.2	
AC mains circuit to earth: BI	1000 Vdc	277 Vac	3.6	5.2	5	5.2	
AC mains circuit to Control circuits: BI	1000 Vdc	277 Vac	3.6	See below	5	See below	
-at Trace	1000 Vdc	277 Vac	3.6	5.7	5	5.7	
-at HCTB1-HCTB3	1000 Vdc	277 Vac	3.6	5.2	5	5.2	
-at RB33, RB32, RB137-RB 140	1000 Vdc	277 Vac	3.6	12	5	12	
-at RB35, RB34, RB128-RB 131	1000 Vdc	277 Vac	3.6	12	5	12	
-at RB36, RB37, RB119-RB 122	1000 Vdc	277 Vac	3.6	12	5	12	
-at RB38, RB39, RB109-RB 112	1000 Vdc	277 Vac	3.6	12	5	12	
-at LB7	1000 Vdc	277 Vac	3.6	5.1	5	5.1	
-at RY3	1000 Vdc	277 Vac	3.6	5.5	5	5.5	
AC Filter Board (150-303004-6)							
AC mains circuit to earth: BI	1000 Vdc	277 Vac	3.6	5.2	5	5.2	
Power Board (150-303002-2 v03)							
PV supply terminal “ + “ to “ - “ : FI	1000 Vdc	277 Vac	3.6	5.2	5	5.2	
PV supply circuits to earth: BI	1000 Vdc	277 Vac	3.6	5.2	5	5.2	

7.3.7	TABLE: clearance and creepage distance measurements						P
PV supply circuits to Control circuits: BI	1000 Vdc	277 Vac	3.6	See below	5	See below	
-at Trace	1000 Vdc	277 Vac	3.6	6.4	5	6.4	
-at Transformer TXD1	1000 Vdc	277 Vac	3.6	15	5	15	
-at Transformer TV1 (on 150-203010-3 V1.3 board)	1000 Vdc	277 Vac	3.6	6.2	5	6.2	
-at UD1, UD2	1000 Vdc	277 Vac	3.6	7.4	5	7.4	
-at RD1-RD20	1000 Vdc	277 Vac	3.6	10	5	10	
Control Board (150-303000-2 V03)							
PV supply terminal “ + “ to “ - “ : FI	1000 Vdc	277 Vac	3.6	6.0	5	6.0	
Control circuit to COM/Display circuits: SI	1000 Vdc	277 Vac	3.6	See below	5	See below	
-at TC1	1000 Vdc	277 Vac	3.6	10.1	5	10.1	
-at UC63, UC64, UC67, UC68, UC70, UC71	1000 Vdc	277 Vac	3.6	7.7	5	8.0	
PV supply circuits to Control circuits: BI	1000 Vdc	277 Vac	3.6	See below	5	See below	
-at Trace	1000 Vdc	277 Vac	3.6	5.7	5	5.7	
-at TC1	1000 Vdc	277 Vac	3.6	8.4	5	8.4	
-at UC11, UC12	1000 Vdc	277 Vac	3.6	7.6	5	7.6	
-at CC85	1000 Vdc	277 Vac	3.6	5.7	5	5.7	
PV Combine Board (150-303005-3 V04)							
PV supply terminal “ + “ to “ - “ : FI	1000 Vdc	277 Vac	3.6	5.9	5	5.9	
PV supply circuits to earth: BI	1000 Vdc	277 Vac	3.6	5.2	5	5.2	
Control circuits to COM/Display circuits: SI	1000 Vdc	277 Vac	3.6	See below	5	See below	
-at UF4, UF6, UF7	1000 Vdc	277 Vac	3.6	7.7	5	8.0	
-at Trace	1000 Vdc	277 Vac	3.6	6.2	5	6.2	
PV supply circuits to Control circuits: BI	1000 Vdc	277 Vac	3.6	See below	5	See below	
-at Trace	1000 Vdc	277 Vac	3.6	5.3	5	5.3	
-at UF15-UF22	1000 Vdc	277 Vac	3.6	8.0	5	8.0	
-at RF171-RF175, RF190-RF194	1000 Vdc	277 Vac	3.6	10.0	5	10.0	
-at RF159-RF163, RF154-RF158, RF164-RF168, RF6, RF111, RF119, RF131, RF142, RF176-RF180, RF185-RF189	1000 Vdc	277 Vac	3.6	10.0	5	10.0	
Communication Board (150-000000-1 V02)							

7.3.7	TABLE: clearance and creepage distance measurements						P
Control circuit to COM/Display circuits: SI	1000 Vdc	277 Vac	3.6	See below	5	See below	
-at UT4	1000 Vdc	277 Vac	3.6	7.7	5	8.0	
-at Trace	1000 Vdc	277 Vac	3.6	9.5	5	9.5	
Independence components							
IGBT	1000 Vdc	277 Vac	3.6	11.3	10	11.3	
DC Switch	1000 Vdc	277 Vac	3.6	>30	10	>30	
<p>Note(s):</p> <p>VMAX PV (V) = 1000 Vd.c, AC output voltage = 480 Va.c;</p> <p>PV supply circuits = O.V.C II, AC mains circuits = O.V.C. III.</p> <p>PD = PD2 (IP65), MG = IIIa/b, Altitude = 2000m (1.0 factor)</p> <p>Communication Circuits/ Display Circuits in PCE is considered as DVC-A with reinforced insulation from DVC-C circuits.</p> <p>Communication and display circuits in PCE are considered as DVC-A which could be accessible.</p> <p>PV side: SPD were provided between PV circuits and earth.</p> <p>Grid side: SPD were provided between AC mains circuits and mains to earth as well.</p> <p>1. Annex I of SPD or varistor for reducing impulse voltage was considered in this test report.</p> <p>2. Functional insulation was shorted circuit tests and consideration. see sub-clause 5.3.4 c).</p> <p>Circuit breakers are required both to PV input and Grid output side in final installation.</p>							

7.3.7	TABLE: distance through insulation measurement				P
distance through insulation di at/of:		U r.m.s. (V)	test voltage (V)	required di (mm)	di (mm)
Bobbin of Isolated Transformer TC1		1000 Vdc	6000Vpk	0.2	>0.4

7.5	TABLE: electric strength measurements, impulse voltage test and partial discharge test				P
test voltage applied between:		test voltage (Vdc)	impulse withstand voltage (V)	partial discharge extinction voltage (V)	result
DC input terminal to earthed enclosure		2120	6000V	N/A	No breakdown
AC output terminal to earthed enclosure		2120	6000V	N/A	No breakdown
DC input terminal to communication port		4240	8000V	N/A	No breakdown
AC output terminal to communication port		4240	8000V	N/A	No breakdown
DC input terminal to LCD screen cover		4240	8000V	N/A	No breakdown
AC output terminal to LCD screen cover		4240	8000V	N/A	No breakdown

9.2	TABLE: Limited power sources					N/A
Circuit output tested:						
Note: Measured Uoc (V) with all load circuits disconnected:						
Components	Sample No.	Uoc (V)	I _{sc} (A)		VA	
			Meas.	Limit	Meas.	Limit
supplementary information:						
Sc=Short circuit, Oc=Open circuit						

14	TABLE: list of critical components					P
object/part No.	manufacturer/ trademark	type/model	technical data	standard	mark(s) of conformity ¹⁾	
DC Input Connector	Stäubli (Hangzhou) Mechatronic Co., Ltd.	MC4 Series	1000Vdc, 39A, Max. 90°C, IP68	EN 50521 UL 6703	TUV R60028286 R60087448 E343181	
	Amphenol Industrial Operations	Helios H4 Series	1000Vdc, 40A , Max.90°C,IP68	EN 50521 UL 6703	TUV R 50157783 UL E339277	
AC Wiring Connector (020.00200018-0)	SCED Electronics Co., Ltd.	TR100-01 (600V 100A)	600V 100A	UL1059	E313040	
DC Switch () 011.00200010-0	Santon International B.V	XBHP3610-2-D	1000VDC/20A,5 00Vdc/45A/6PO LE	DEKRA IEC60947-3 CCC GB14048.3- 2008	2184962.01A 2015010302775 872	
	Bremas Bremas Ersce SpA	DK10016220BM MVU6	1000VDC16A/6 00V40A/6POLE	CCC GB14048.3- 2008	2016010302924 261	
	ProJoy Electric Co., Ltd.	PEDS150R- HM40-6	1000VDC20A/6 00V40A/6POLE	TUV EN60947-3 2009 SAA IEC60947- 3	R50321787 SAA152354	
PV Terminal	Stäubli (Hangzhou) Mechatronic Co., Ltd.	PV-ADBP4- S2/6-UR	1000V dc, 39 A 90 °C , IP65	DIN V VDE V 0126-3/12.2006	TUV R60028286 R60087448 UL E343181	
	Stäubli (Hangzhou) Mechatronic Co., Ltd.	PV-ADSP4- S2/6-UR	1000V dc, 39 A 90 °C , IP65	DIN V VDE V 0126-3/12.2006	TUV R60028286 R60087448 UL E343181	
PCB Material	SHANTOU LUCKY STAR PCB CO LTD	WS888	130°C, V-0, CTI: min.175	UL796	UL E301869	
	Shenzhen Glorysky electronics CO LTD	GS-M	130°C, V-0, CTI: min.175	UL796	E257384	
Gas Discharge	SHENZHEN BENCENT	B8G1500M	1200-1800Vdc, -40-90°C	UL 1449	UL E337906	

14 TABLE: list of critical components					P
object/part No.	manufacturer/ trademark	type/model	technical data	standard	mark(s) of conformity ¹⁾
Tube (GASB1)	ELECTRONIC CO LTD				
Output on-grid Relay (RY1,RY2,RY3, RY4,RY5,RY6)	Xiamen Hongfa Electroacoustic Co.,Ltd.	HF167F	90A 320VAC,Resistive,1k cycles, 85 °C	TUV EN61810-1 2005	TUV R50360703
	Panasonic Industrial Devices Sales (China) Co., Ltd.	HE1aN-W-DC12V-Y6	90A/ 277V AC/ -50°C ~ +85°C	UL60947-4-1	UL E43028
	Churod Electronics Co., Ltd	CHAR-112A100	100A 277V ac - 40°C ~ +85°C	UL60947-4-1 TUV:EN61810-1 2008	UL E341422 TUV R50316974
Current Sensor (HCTB1,HCTB2, HCTB3)	VACUUMSCHMELZE GmbH & Co. KG	T60404-N4646-X461	100A/5V/-40°C ~ +85°C	UL:508	UL E317483
	tamurash shanghai electronics ltd	F23P100S05	100A/5V/-40°C ~ +85°C	UL508	E243511
(Y Capacitor) (CF1,CF2,CF3,C F4,CF5,CF6,CF 7,CF8,CF17,CF 18,CF27,CF28, CF37,CF38,CF4 7,CF48,CF49,C F50,CF51,CF52 ,CF58,CF65,CF 70,CF72, CA10,CA11,CA 16,CA17,CA18, CA19,CA25,CA 26,CA34,CA35, CA40,CA41)	SONGTIAN ENTERPRISE Co.,LTD	CD	4700PF, 400Vac, 125°C	IEC/EN 60384-14 UL60384-14	UL E208107, VDE 40025754 CQC060010186 10
	Vishay Electronic GmbH	VY1	4700PF, 500Vac, 125°C	IEC/EN 60384-14 UL60384-14	UL E183844, VDE 40012673
Voltage Dependent Resistor (MOV B1, MOV B2, MOV B3,	Littelfuse, Inc	V1000LA160BP	1000Vac,1200V dc, 85 °C	UL 1414 IEC/EN 61051-1, IEC/EN 61051-2.	UL E320116 VDE 116895
		TVR20561KSY	1000Vac ,	UL 1414	UL E314979

14 TABLE: list of critical components						P
object/part No.	manufacturer/ trademark	type/model	technical data	standard	mark(s) of conformity ¹⁾	
MOVB4)	THINKING ELECTRONIC INDUSTRIAL CO., LTD.		85°C			
Input Common- mode Inductor (LA1,LA2,LA3)	Huizhou baohui electronics technology co., ltd	115-17-019A	580uH/M12K	NB/T 32004- 2013	Together with machine	
	Yindate electronics Huizhou ltd	115-17-019A	580uH/M12K	NB/T 32004- 2013	Together with machine	
IGBT Module	Infineon Electronic GmbH	DS_F3L200R12 W2H3_B11_EN G_1_1_de-en	200A/1200V/Ea sy 2B	---	---	
	Vincotech Electronic GmbH	10- xY12NMA160S H01-M820F18x- D2-14-1	160A/1200V/Flo w1	---	---	
	Vincotech Electronic GmbH	30- FT12NMA160S H02-M669F28- PM	160A/1200V/Flo w2	---	---	
SiC MOS (QD1,QD2,QD3, QD12,QD13,QD 14,QD8,QD9,Q D10)	ROHM Co., Ltd.	SCT2080KE	NMOS/28A/120 0V/TO247	---	---	
	Cree, Inc.	C2M0080120D	NMOS/20A/120 0V/TO247-3	---	---	
SiC Diode(DD14,DD 15,DD20,DD21, DD29,DD30)	Cree, Inc.	C4D15120D	24A/1200V/TO- 247	---	---	
	Cree, Inc.	C4D20120D	32A/1200V/TO- 247	---	---	
	ROHM Co., Ltd.	SCS230KE2C	30A/1200V/TO- 247	---	---	
Bus Capacitor (CD13,CD14,CD 15,CD17,CD18, CD19,CD21,CD 22,CD24,CD25, CD26,CD72)	KEMET Electronics Italia S.r.l.	C4AELBW6110 A3NK	500V110uF at 85°C,2.5mOhm	NB/T 32004- 2013	Together with machine	
	Panasonic Industrial Devices Sales (China) Co., Ltd.	EZPE55117MT A	500V110uF at 85°C,4.4mOhm	NB/T 32004- 2013	Together with machine	
	Xiamen faratronic co,ltd	C3D1U117JM0 AC00	600V 110uF at 85°C 3.8m Ohm	NB/T 32004- 2013	Together with machine	

14 TABLE: list of critical components					P
object/part No.	manufacturer/ trademark	type/model	technical data	standard	mark(s) of conformity ¹⁾
	HUAJUNG COMPONENTS CO.,LTD.	EPB- 117K0600DB15 2B-FF	600V 110uF at 85°C4m Ohm	NB/T 32004- 2013	Together with machine
	Cree, Inc.	DMJ- PS110UF500V	500V110uF at 85°C,4.4mOhm	NB/T 32004- 2013	Together with machine
Bus Electrolytic Capacitor (ECD1, ECD2, ECD3, ECD4, ECD5, ECD6, ECD7, ECD8, ECD9, ECD10, ECD11, ECD12, ECD13, ECD14, ECD15, ECD16)	Nichicon corporation	LGX2H471MEL C58	470uF/500V/Φ3 5*58/5000H	NB/T 32004- 2013	Together with machine
	UNICON corporation	LLN2H471M356 0	470uF/500V/Φ3 5*60/5000H	NB/T 32004- 2013	Together with machine
	Man Yue Electronics Company Limited	EEP477V2HQ5 0SW**P	470uF/500V/Φ3 5*50/5000H	NB/T 32004- 2013	Together with machine
small chip inductor (LB5, LC6,LC11,LC13 ,LC20,LC21,LT1 ,LF2)	Huizhou baohui electronics technology co., ltd	SH-L006	39uH,DR10*5.4 RB K38 /RI10*3.4 *8.2 K38 ,130°C	NB/T 32004- 2013	Together with machine
optical-coupler (UC11,UC12,UC 63,UC64,UC67, UC68,UC70,UC 71, UF4,UF6,UF7)	Toshiba Corporation	TLP785F(D4GR T7.F(C	Isolation voltage: 5000Vrms 85 °C	UL1577	UL E67349
	LITE-ON TECHNOLOGY CORPORATIO N	LTV816S2TPB- V	Isolation voltage: 5000Vrms 110 °C	DIN EN 60747- 5-5	VDE 40015248
Driver Transformer (TV1)	Huizhou baohui electronics technology co., ltd	SH-T002	Class B , 130°C	NB/T 32004- 2013	Together with machine
	boluodaxin electronics	SH-T002	Class B , 130°C	NB/T 32004- 2013	Together with machine
X Capacitor (CB1,CB2,CB3)	Xiamen faratronic co,ltd	C42Q2475MBF C000	X2/4.7uF/305VA C/±20%/32*14* 28,P=27.5mm/ MKP62	CQC (GB/T 6346.14 (IEC60384-14)) UL-CUL (UL60384- 14:2014)	CQC030010028 75 E186600
	TDK China Co	B32924D3475K	X2/4.7uF/305VA	CQC (GB/T	CQC060010153

14 TABLE: list of critical components					P
object/part No.	manufacturer/ trademark	type/model	technical data	standard	mark(s) of conformity ¹⁾
	Ltd	000	C/±10%/21*31* 31.5/2pin	14472-1998) UL 1414 / UL 1283	31 E97863 / E157153
	SONGTIAN ENTERPRISE Co.,LTD	MPX	X2, 2.2uF, 305Vac	UL 60384-14 IEC 60384-14	UL E208107 VDE 40034679
Y Capacitor (CYB1, CYB2, CYB3 , CYB4, CYB5, CYB6, CYB7)	SONGTIAN ENTERPRISE Co.,LTD	CE	Y2, 250Vac, 10000pF, 125°C	UL 60384-14, IEC 60384-14	UL E208107 VDE 40025748 CQC070010199 06
	Xiamen faratronic co,ltd	C43Q1103M40 C000	Y2/10nF/300VA C/13*12*6.0	UL/CUL : 60384-14,	UL E186600
ISO Relay (RYA1,RYA2)	Fujitsu Component Limited	NA5W-K	2A/220VDC/5V DC/2C	UL508	UL E45026
	Xiamen Hongfa Electroacoustic Co.,Ltd.	HFD3/5	5Vdc/2A/30Vdc	---	---
Input Current Sensor (HCTA1 , HCTA2 , HCTA3)	LEM Electronics (China) Co. Ltd	HXN 50-P	50A/±12V/1%/1 9x15x20mm	UL508	UL E189713
	tamurash shanghai electronics ltd	L18P050 D15- OP	50A/±12V/1%/1 7x15x17.5mm	UL508	UL E243511
Output Common-mode Inductor (LB2)	tamurash shanghai electronics ltd	CF501900- H00TS	50-70KW Common-mode Inductor /0.50mH/90A	NB/T 32004- 2013	Together with machine
	Huizhou baohui electronics technology co., ltd	115-17-031A	50-70KW , Output three- winding common-mode inductance/90A/ 490UH	NB/T 32004- 2013	Together with machine
Boost Inductor (60K,70K)	Huizhou baohui electronics technology co., ltd	DCL40A244uH	DCL40A244uH at 40A	NB/T 32004- 2013	Together with machine
	HeFei ECU- TAMURA		DCL40A244uH at 40A	NB/T 32004- 2013	Together with machine

14	TABLE: list of critical components					P
object/part No.	manufacturer/ trademark	type/model	technical data	standard	mark(s) of conformity ¹⁾	
	Electric Co.,Ltd					
	yunlu Qingdao green energy ltd		DCL40A244uH at 40A	NB/T 32004- 2013	Together with machine	
	tamurash shanghai electronics ltd		DCL40A244uH at 40A	NB/T 32004- 2013	Together with machine	
Boost Inductor (50K)	Huizhou baohui electronics technology co., ltd	DCL30A287uH	DCL30A287uH	NB/T 32004- 2013	Together with machine	
	HeFei ECU- TAMURA Electric Co.,Ltd		DCL30A287uH	NB/T 32004- 2013	Together with machine	
	yunlu Qingdao green energy ltd		DCL30A287uH	NB/T 32004- 2013	Together with machine	
	tamurash shanghai electronics ltd		DCL30A287uH	NB/T 32004- 2013	Together with machine	
Inverter Inductor (60K,70K)	HeFei ECU- TAMURA Electric Co.,Ltd	ACL90A120uH	120.3 uH min@128.6A Class B	NB/T 32004- 2013	Together with machine	
	Huizhou baohui electronics technology co., ltd		120.3 uH min@128.6A Class B	NB/T 32004- 2013	Together with machine	
	yunlu Qingdao green energy ltd		120.3 uH min@128.6A Class B	NB/T 32004- 2013	Together with machine	
	tamurash shanghai electronics ltd		120.3 uH min@128.6A Class B	NB/T 32004- 2013	Together with machine	
Inverter Inductor (50K)	HeFei ECU- TAMURA Electric Co.,Ltd	ACL76A160uH	L=160uH at 107A , Class B	NB/T 32004- 2013	Together with machine	
	Huizhou baohui electronics technology co., ltd		L=160uH at 107A , Class B	NB/T 32004- 2013	Together with machine	

14 TABLE: list of critical components					P
object/part No.	manufacturer/ trademark	type/model	technical data	standard	mark(s) of conformity ¹⁾
	yunlu Qingdao green energy ltd		L=160uH at 107A , Class B	NB/T 32004- 2013	Together with machine
	tamurash shanghai electronics ltd		L=160uH at 107A , Class B	NB/T 32004- 2013	Together with machine
Auxiliary Power Transformer	Huizhou baohui electronics technology co., ltd	SH-T002	3.3mH/ETD39H/ PC40/ Horizontal	NB/T 32004- 2013	Together with machine
	yingdate Huizhou electronics		3.3mH/ETD39H/ PC40/ Horizontal	NB/T 32004- 2013	Together with machine
GFCI Transformer	Huizhou baohui electronics technology co., ltd	115-17-020A	MP2303- 4AS/HITACHI	NB/T 32004- 2013	Together with machine
	yingdate Huizhou electronics		MP2303- 4AS/HITACHI	NB/T 32004- 2013	Together with machine
	NAMIN TECHNOLOGY		MP2303- 4AS/HITACHI	NB/T 32004- 2013	Together with machine
Internal Fan	MinebeaMitsumi Inc.	4710KL-04W- B29-E51	12VDC/2.28W/1 20*120*25	UL UL507 VDE EN60950- 1	UL E89936 VDE 1507300
External Fan	MinebeaMitsumi Inc.	08025VE12PGL D1	08025VE12PGL D1/12V/0.57A/6. 84W/80*80*25	cULus File No.UL507 VDE File No EN60950-1	UL E89936 VDE 1507300
	MinebeaMitsumi Inc.	08025VE-12M- CTD-1	08025VE-12M- CTD- 1/12V/0.23A,/2. 76W/80*80*25	cULus File No.UL507 VDE File No EN60950-1	UL E89936 VDE 1507300

¹⁾ an asterisk indicates a mark which assures the agreed level of surveillance

List of test equipment used:

A completed list of used test equipment shall be provided in the Test Reports when a Manufacturer Testing Laboratory according to CTF stage 1 or CTF stage 2 procedure has been used.

Note: This page may be removed when CTF stage 1 CTF stage 2 are not used. See also clause 4.8 in OD 2020 for more details.

Clause	Measurement / testing	Testing / measuring equipment / material used, (Equipment ID)	Range used	Last Calibration date	Calibration due date
4.3	Thermal testing	Data Acquisition/Switch Unit (GZE100-4)	20~60 channel, 6.5bit, accuracy 0.1°C	2018/7/5	2019/7/4
4.4.4	Testing in single fault condition	Precision Power Analyzer (EP-011)	(DCV):0.006% (ACV):0.05% (DCA):0.06% (ACA):0.08% (DC power):0.08% (AC power):0.1% (Frequency):0.02% (flicker): 0.25	2018/8/6	2019/8/6
4.5	Humidity preconditioning test	Programmable Temperature & Humidity Test Chamber (GZE015-2)	(- 40~ +150) °C / 0.5°C (25~ 98)%RH /2%RH, 408L/(600*800*850)m m, 10KW 380V,50Hz	2018/3/11	2019/3/11
4.6	Backfeed voltage protection test	Precision Power Analyzer (EP-011)	(DCV):0.006% (ACV):0.05% (DCA):0.06% (ACA):0.08% (DC power):0.08% (AC power):0.1% (Frequency):0.02% (flicker): 0.25	2018/8/6	2019/8/6
4.7.2	Electrical ratings test	Precision Power Analyzer (EP-011)	(DCV):0.006% (ACV):0.05% (DCA):0.06% (ACA):0.08% (DC power):0.08% (AC power):0.1% (Frequency):0.02% (flicker): 0.25	2018/8/6	2019/8/6
5	Marking Durability test	Stop Watch (GZE027-22)	accuracy 0.01s	2018/3/31	2019/3/31
6.3	Ingress protection test	IPX5 Test Apparatus (GZE061-29)	D=6.3mm water delivery rate=12.5l/min	2018/6/13	2019/6/13
		Dust chamber (GZE061-22)	1000*1000*1000mm	2018/7/7	2019/7/7
7.3.4	Protection against direct contact	Jointed Test Finger (GZE018-34)	L=180mm, r=6/4/2mm	2018/9/6	2019/9/6
		Test pin (GZE018-38)	IEC60335-1: Figure 2	2018/11/24	2019/11/24

7.3.6.3.4	Earth continuity	Earthing Tester (GZE002-1)	Resistance	(3.0~60)A, (1~510/150)mΩ, (1~999.9)s, 50/60Hz	2018/5/15	2019/5/15
7.3.6.3.5	Cross-sectional protective earthing conductor	Earthing Tester (GZE002-1)	Resistance	(3.0~60)A, (1~510/150)mΩ, (1~999.9)s, 50/60Hz	2018/5/15	2019/5/15
7.3.7.4	Clearance distances	Digital Caliper (GZE016-29)		150mm accuracy 0.01mm	2018/1/3	2019/1/3
7.3.7.5	Creepage distances	Digital Caliper (GZE016-29)		150mm accuracy 0.01mm	2018/1/3	2019/1/3
7.5.1	Impulse voltage test	Impulse tester (EP-048)		15kV	2018/8/6	2019/8/6
7.5.2	Voltage test (dielectric strength test)	Withstanding Voltage Tester (ES-029)	Voltage	Test voltage range: 5kVAC,2.5kVAC; 5kVDC,2.5kVDC; Upper cutoff current range:0.1-11mA,0.1-110mA	2018/8/6	2019/8/6
7.5.4	Touch current measurement (Annex H)	Touch current tester (ES-017)		10mA dc, 10mA ac 300V	2018/11/8	2019/11/8
8.4	Provisions for lifting and carrying	Stop Watch (GZE027-22)		accuracy 0.01s	2018/3/31	2019/3/31
8.5	Wall mounting	Stop Watch (GZE027-22)		accuracy 0.01s	2018/3/31	2019/3/31
10.2.1	Hazardous noise levels	Sound Level Meter (EP-024)		31.5-8000Hz	2018/9/8	2019/9/7
13.7.2	250N deflection test	Pull-Push Scale (GZE034-8)		0 to 500 N	2018/6/12	2019/6/11
		Stop Watch (SA036-46)		accuracy 0.01s	2018/3/31	2019/3/31
13.7.3	7J impact test	Steel Ball (GZE045-4)		Φ50.8mm/535g	2017/2/22	2020/2/22
		Steel ruler (GZE078-1)		200mm	2018/6/13	2019/6/13

-----End of report-----

Attachment I

(Pictures of the EUT and Electrical Schemes)

1.1 PICTURES

General view



Back view

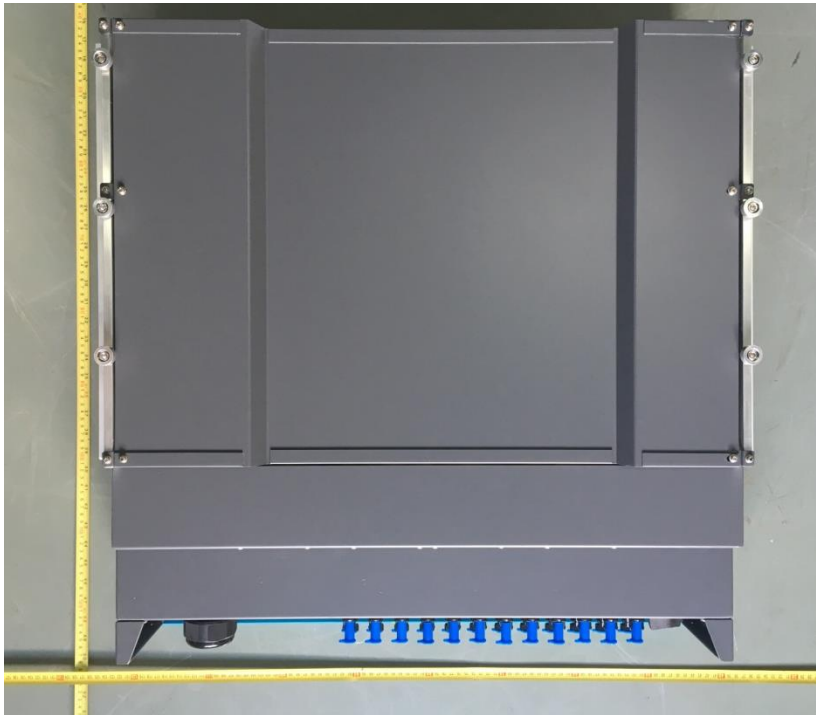

Front view of Main board

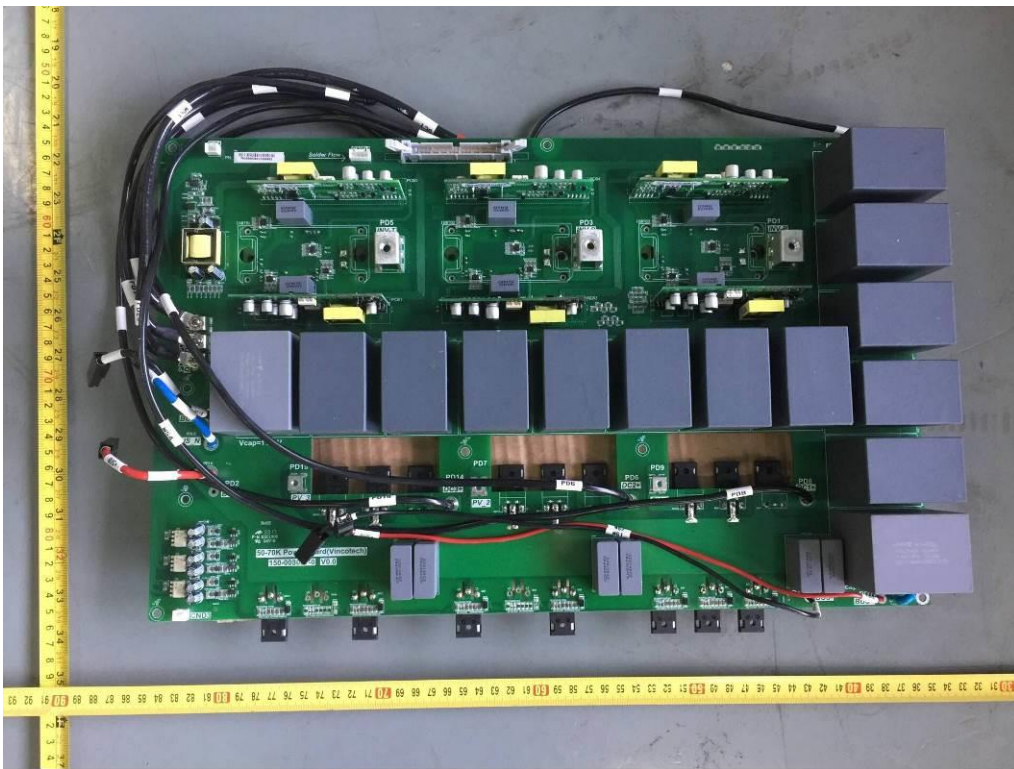

Back view of Main board

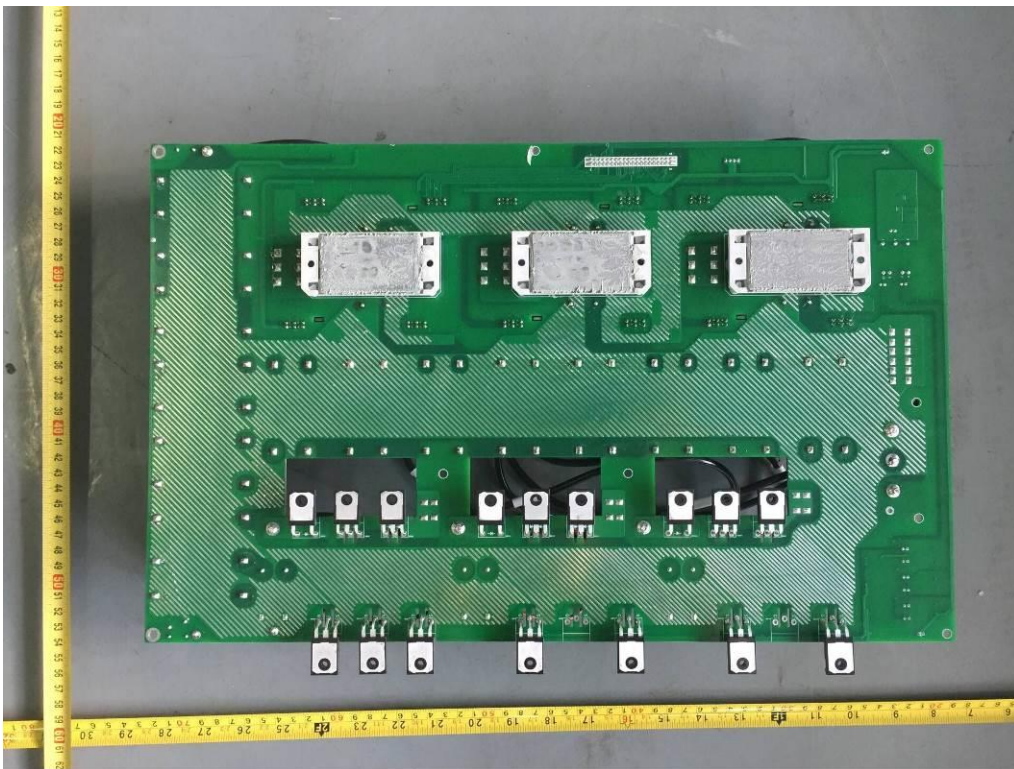

Front View of LCD board

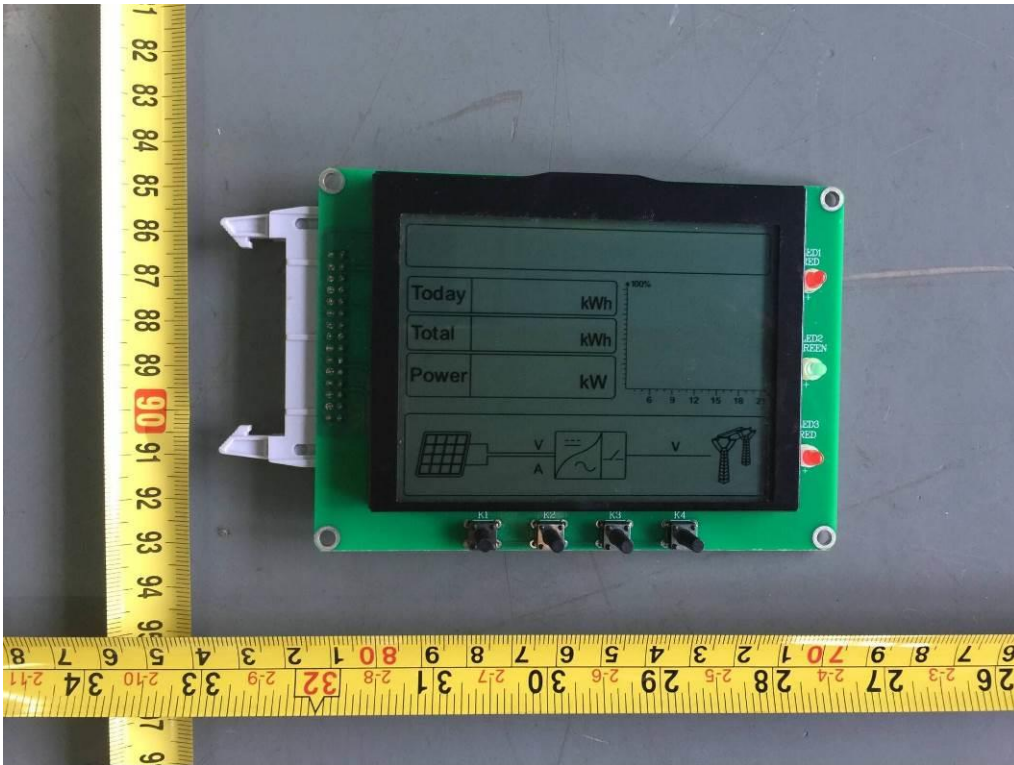

Back View of LCD board

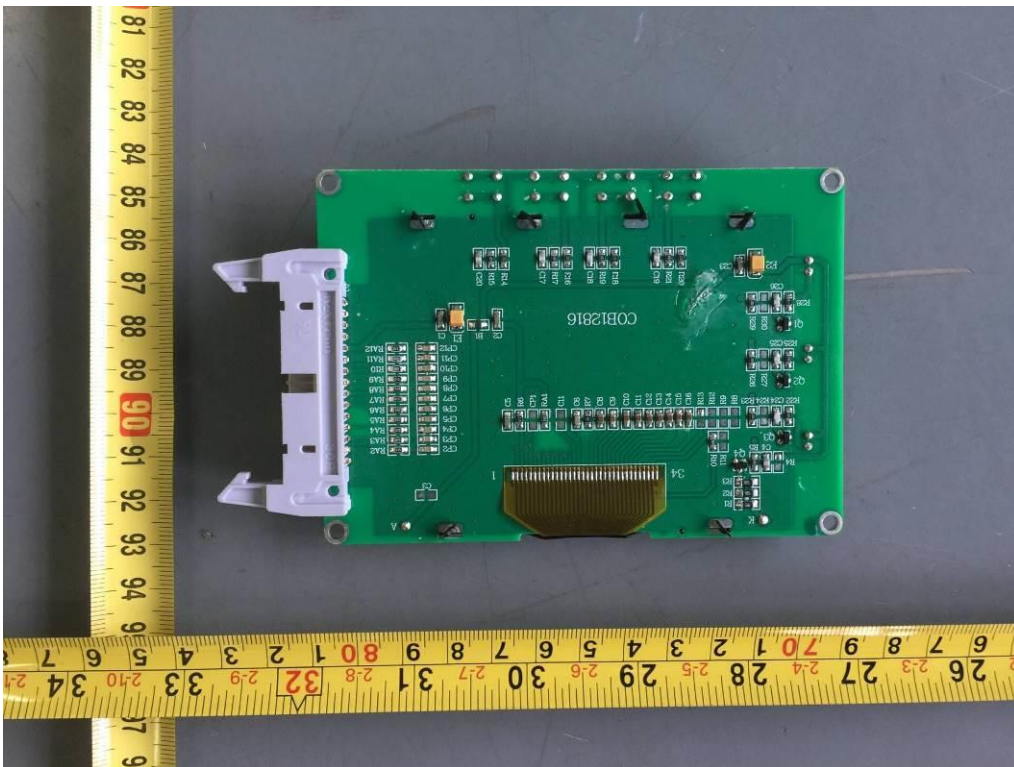

Front View of Control board

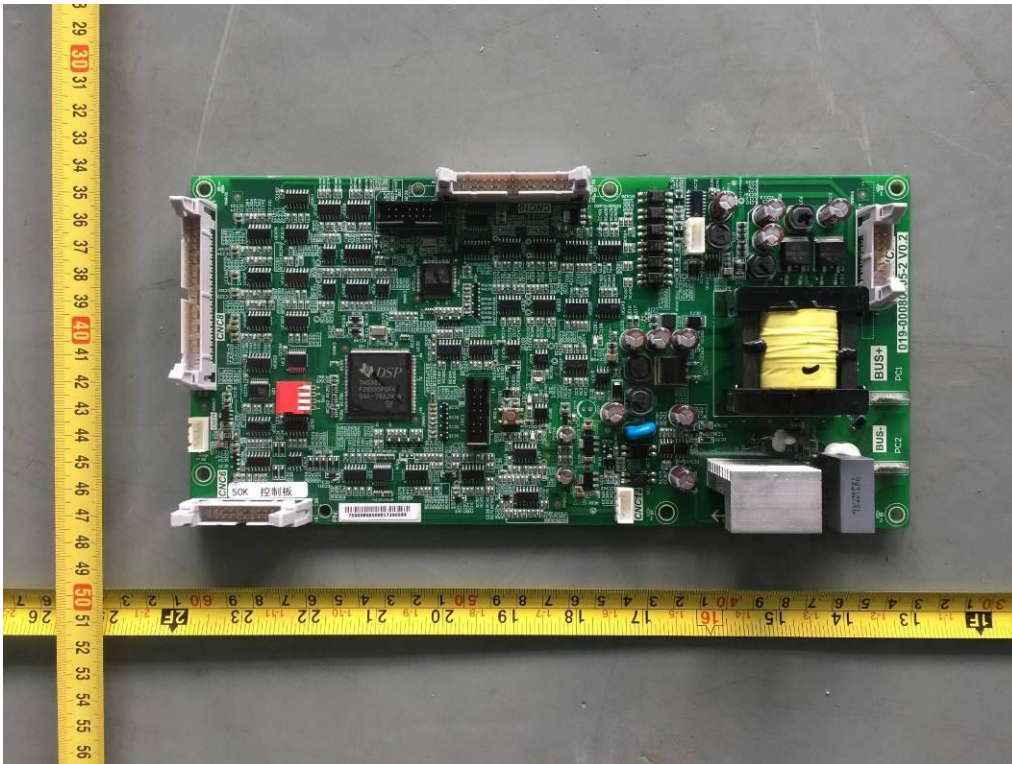

Back View of Control board

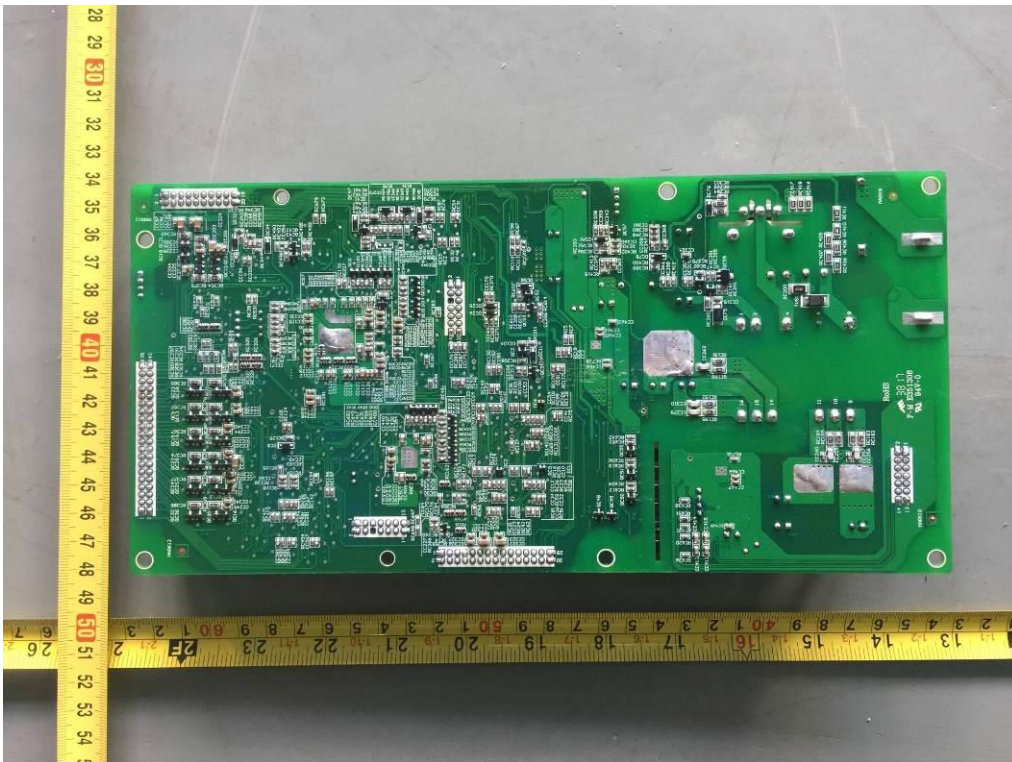

Front View of AC output board

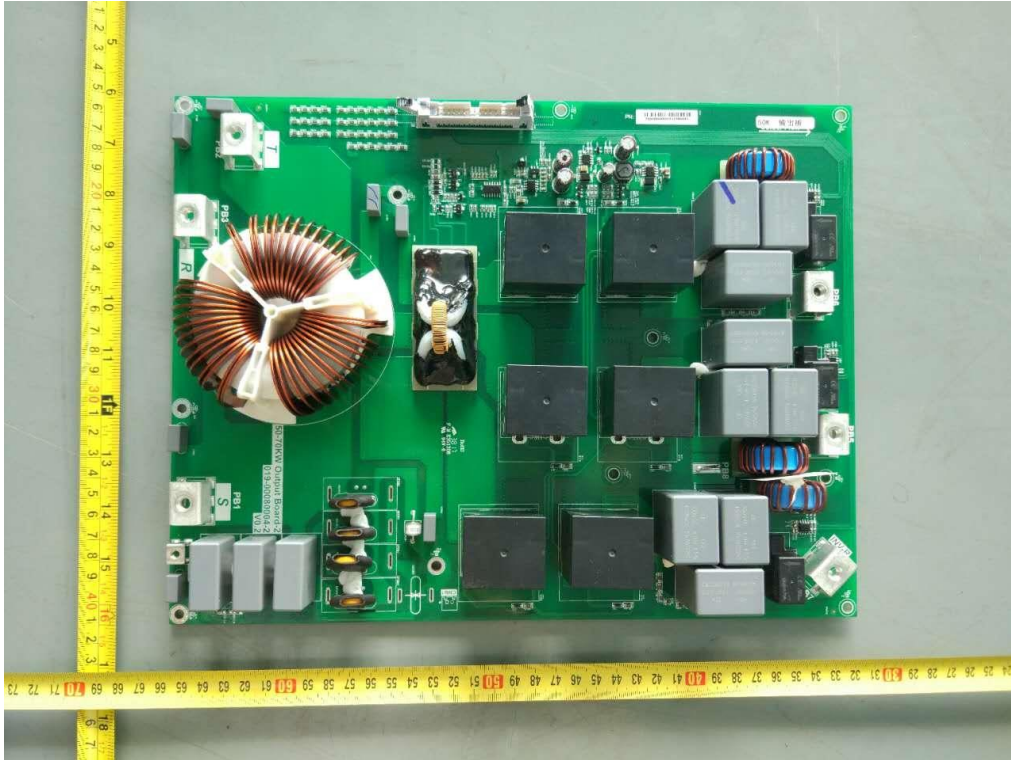

Back View of AC output board

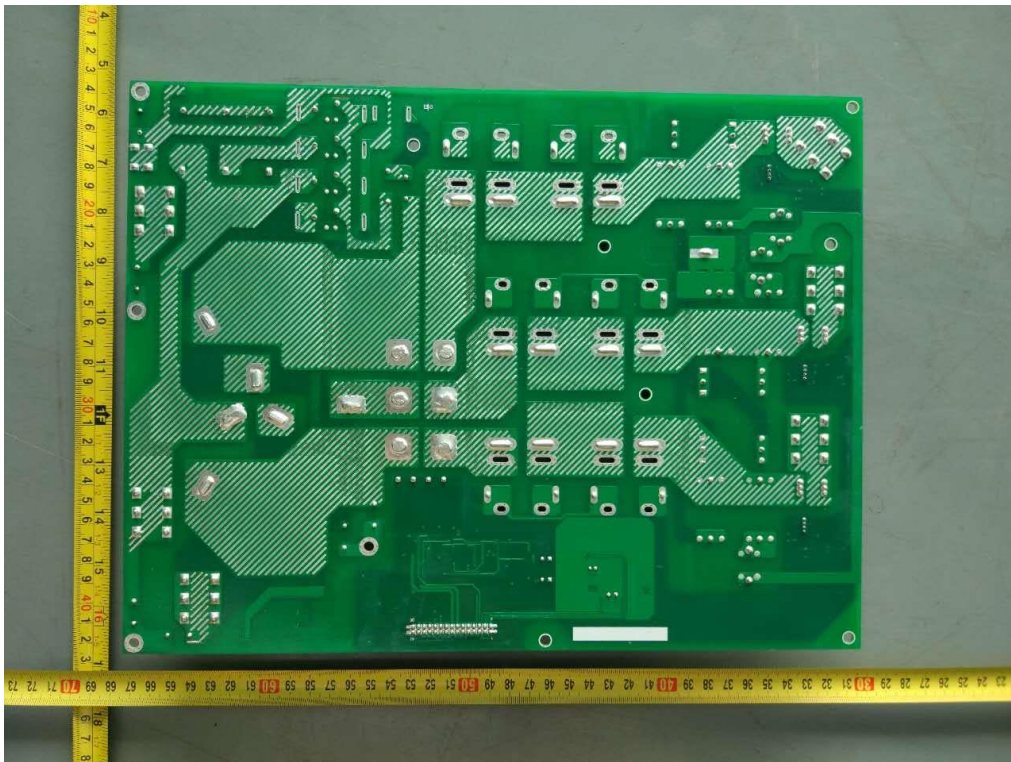

Front View of DC input board

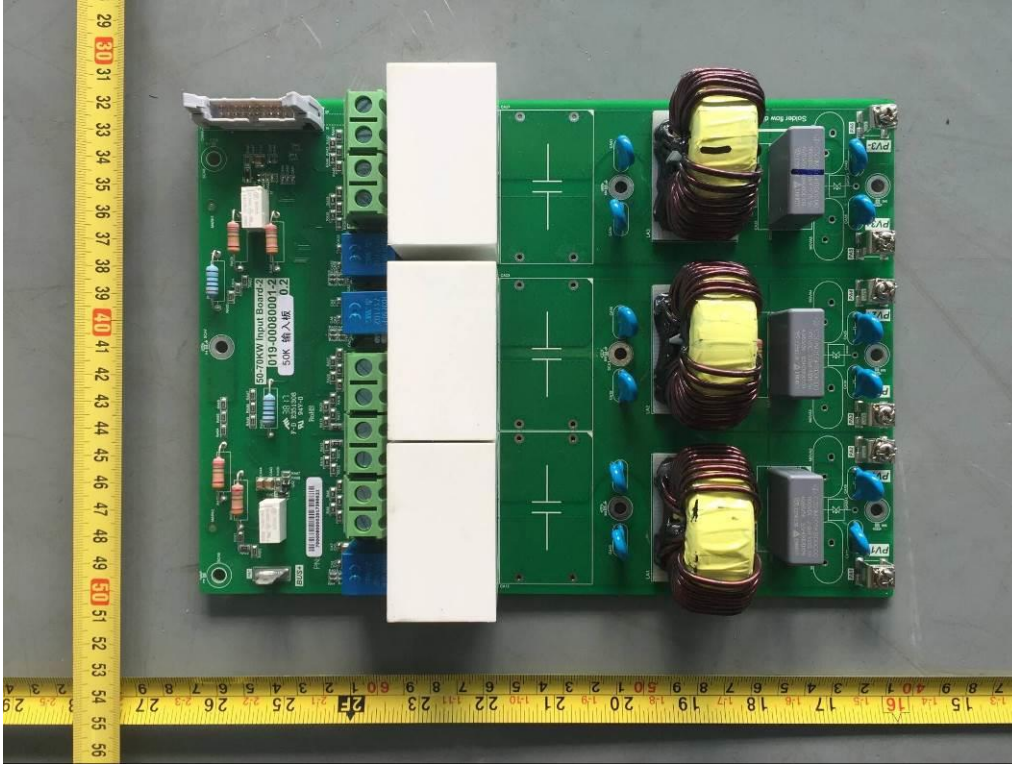

Back View of DC input board

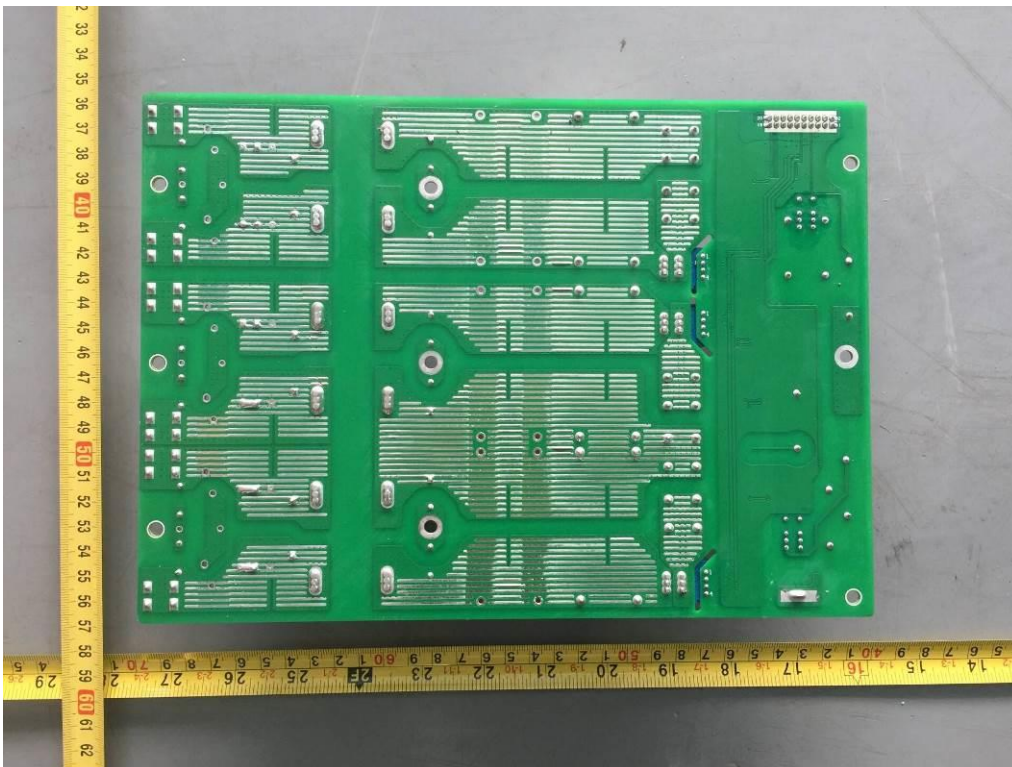

Front View of Communication board

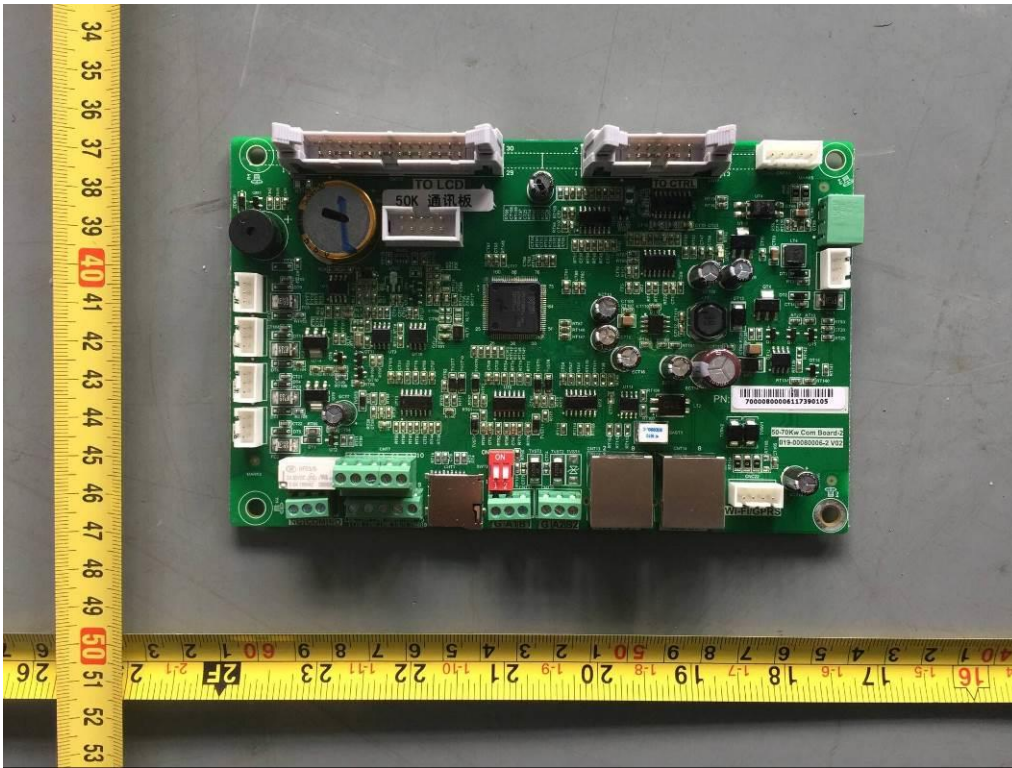

Back View of Communication board

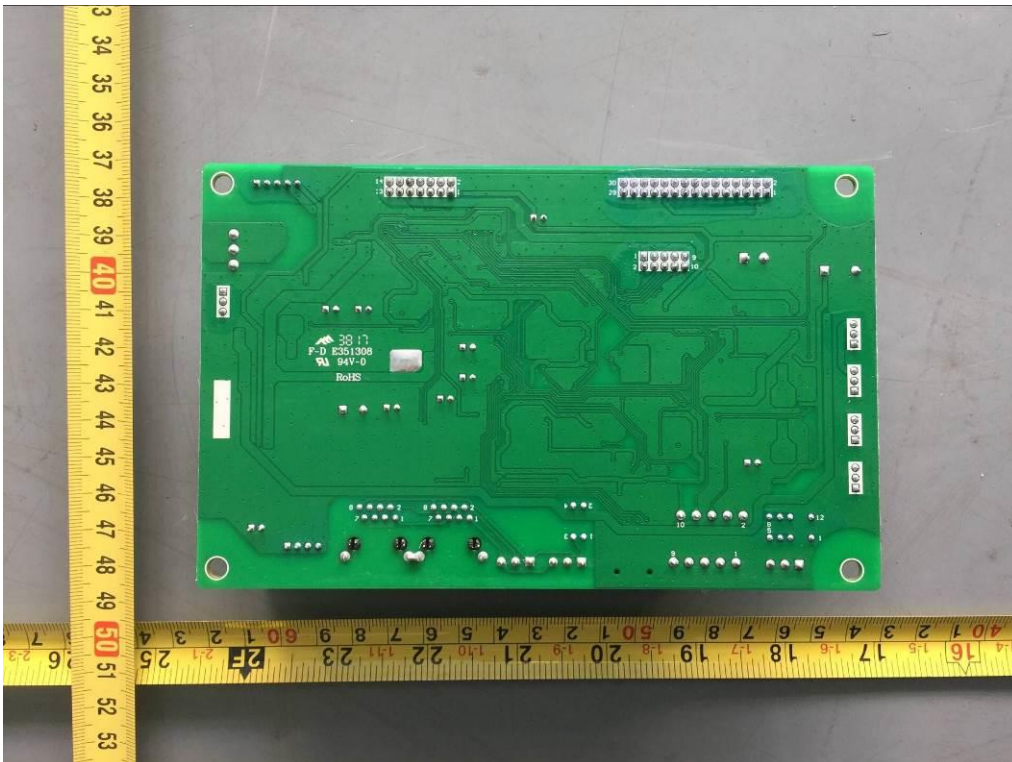

Front View of DC combine board

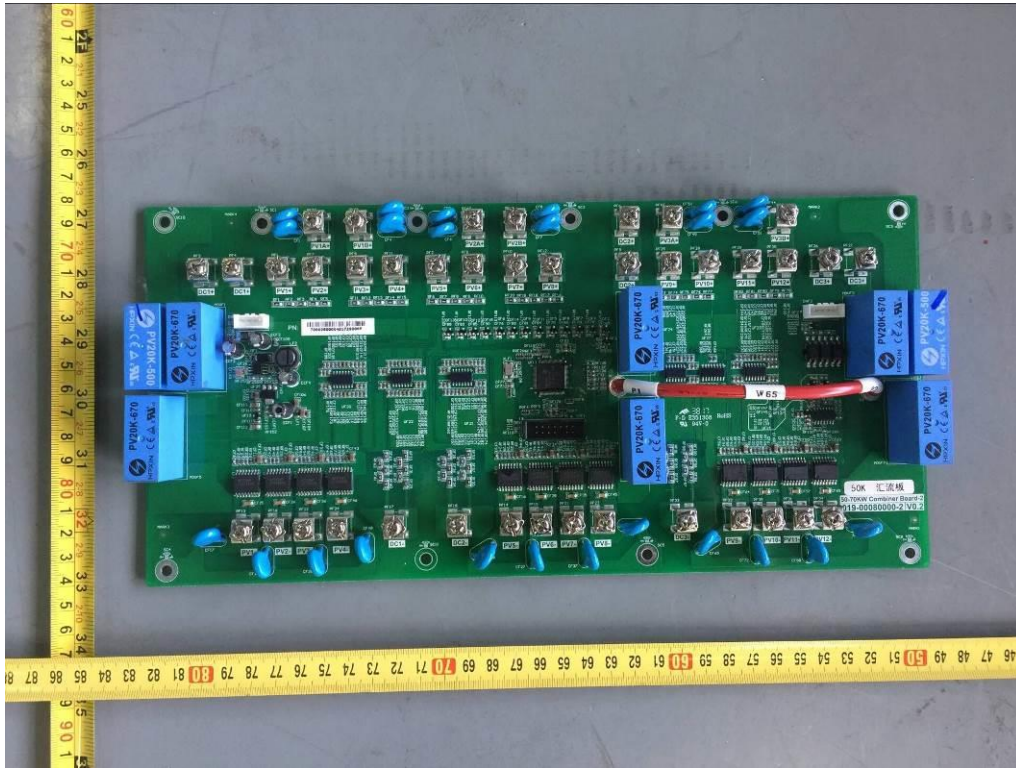

Back View of DC combine board

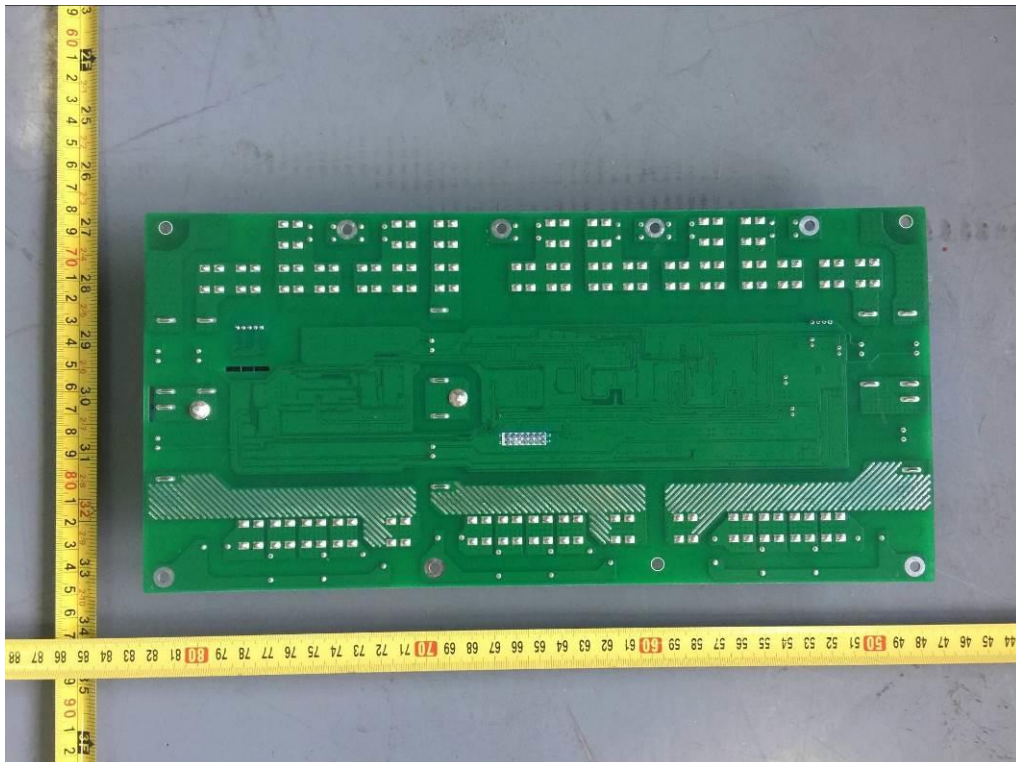

Front View of EVVO 60000TL3P, EVVO 70000TL3P-HV Cap. board

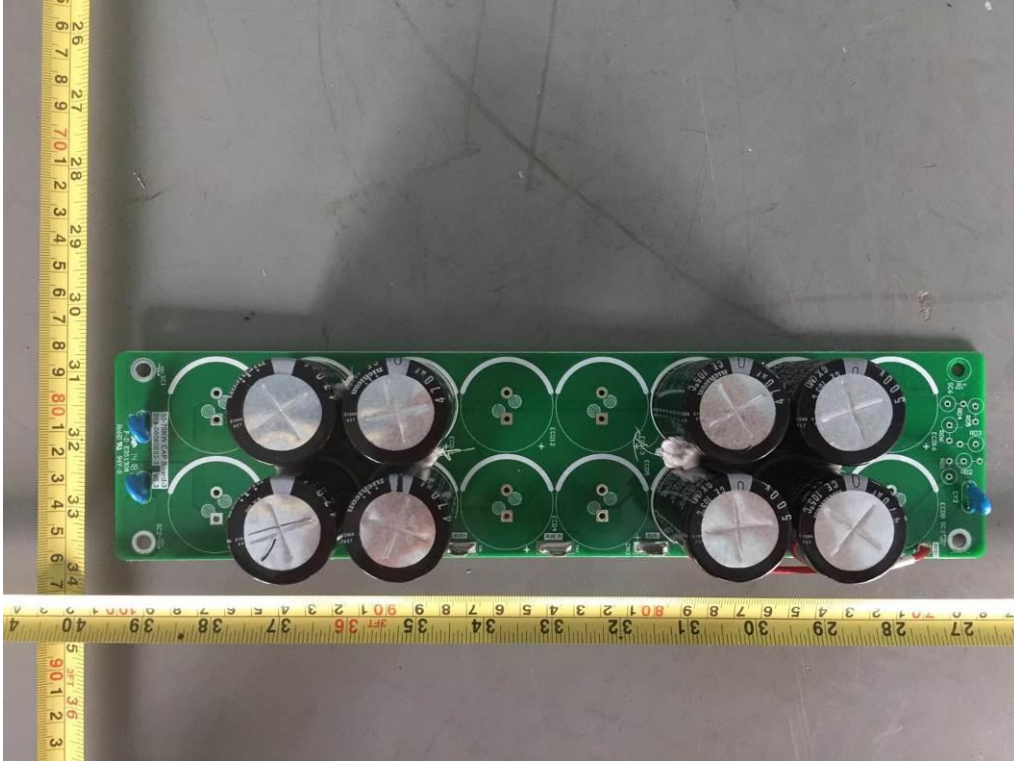

Back View of EVVO 60000TL3P, EVVO 70000TL3P-HV Cap. board

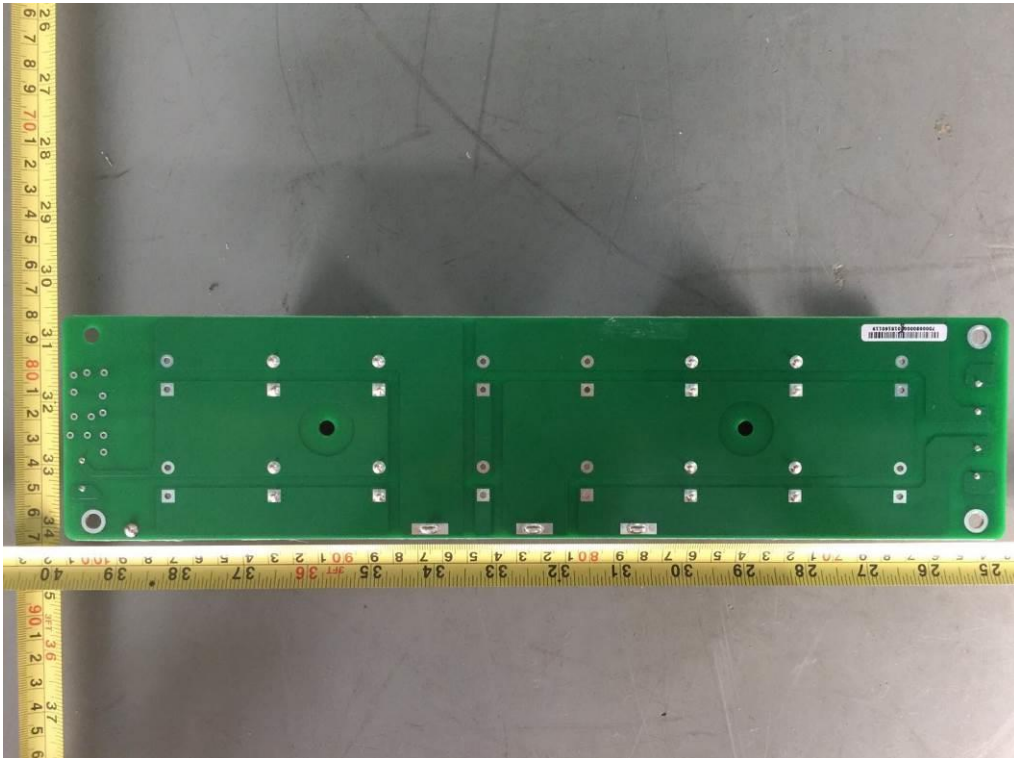

Front View of EVVO 50000TL3P Cap. board



Back View of EVVO 50000TL3P Cap. board

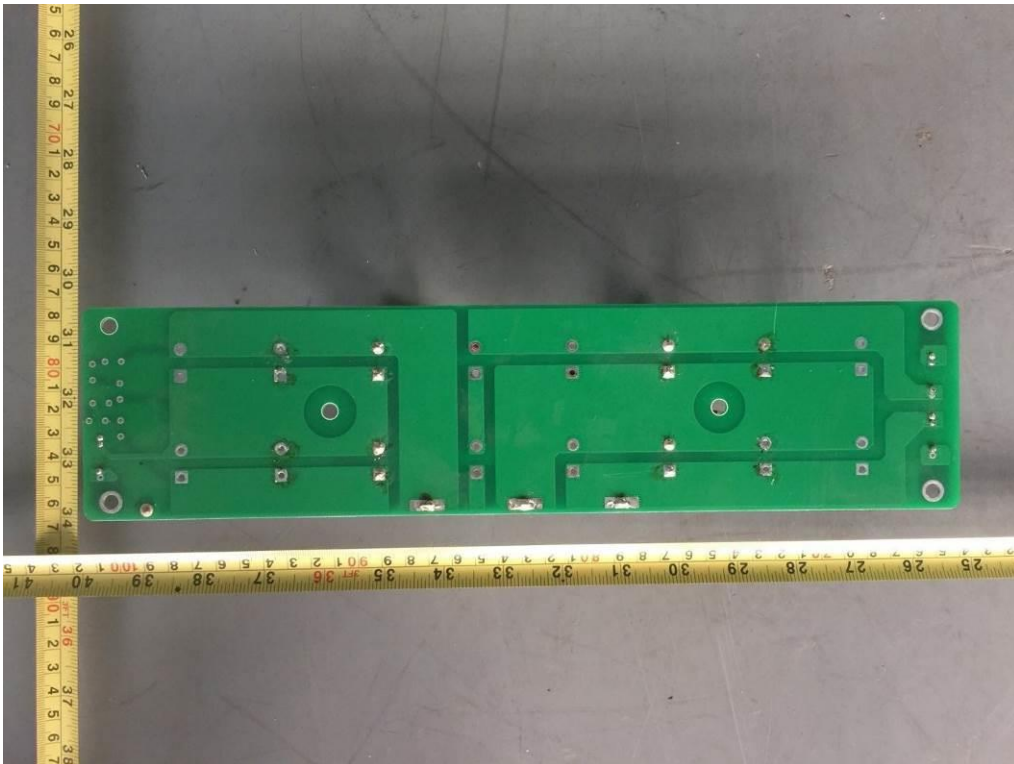

Front View of RS232 board

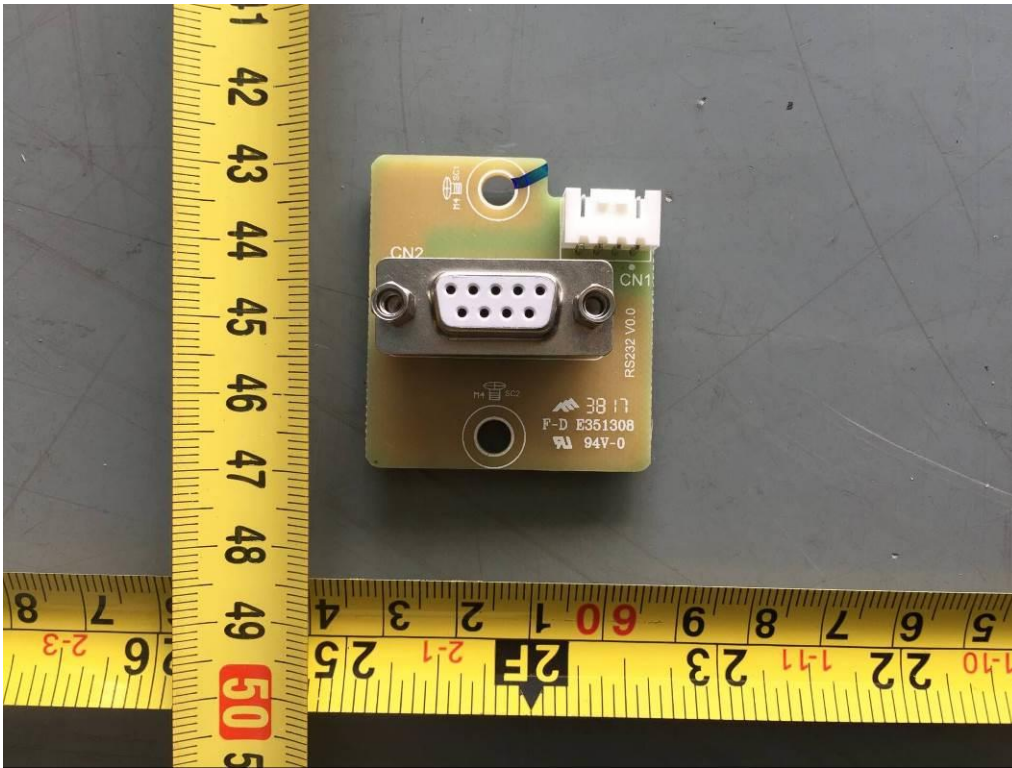

Back View of RS232 board

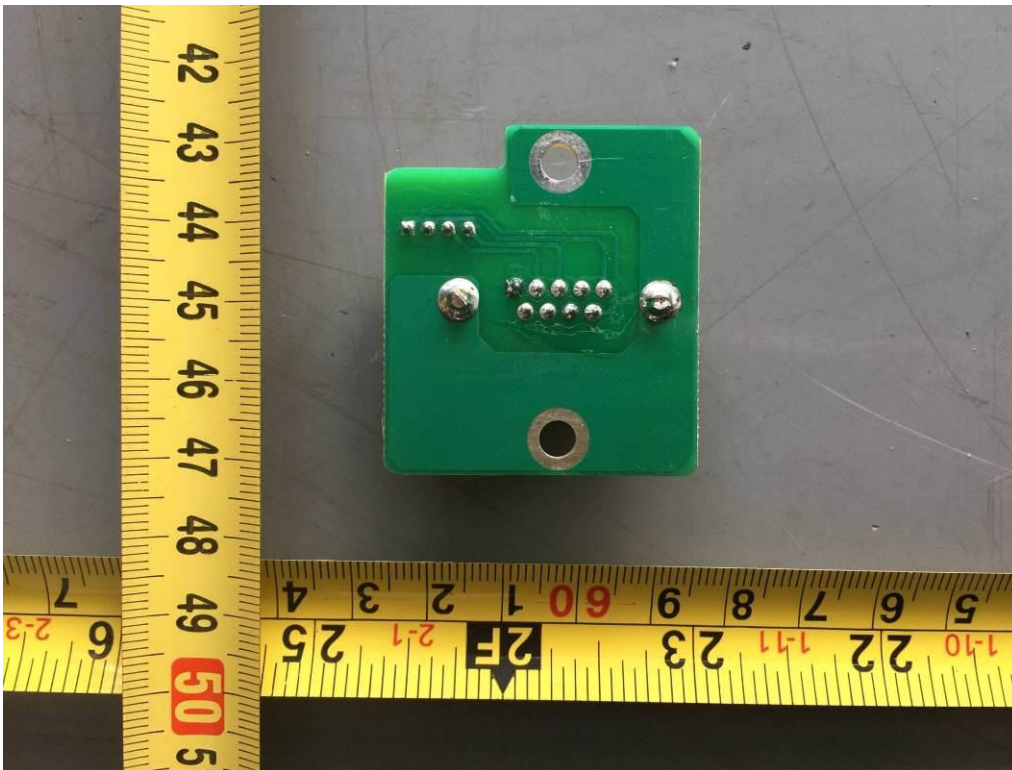

Internal View

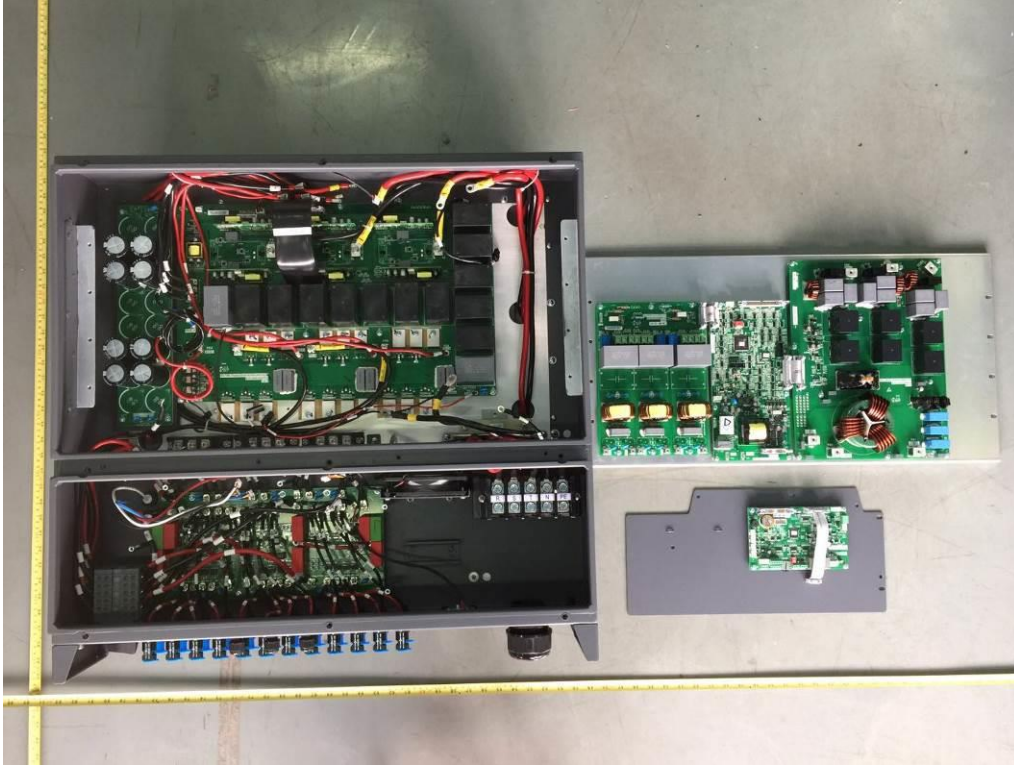

Connection interface



AC output connection

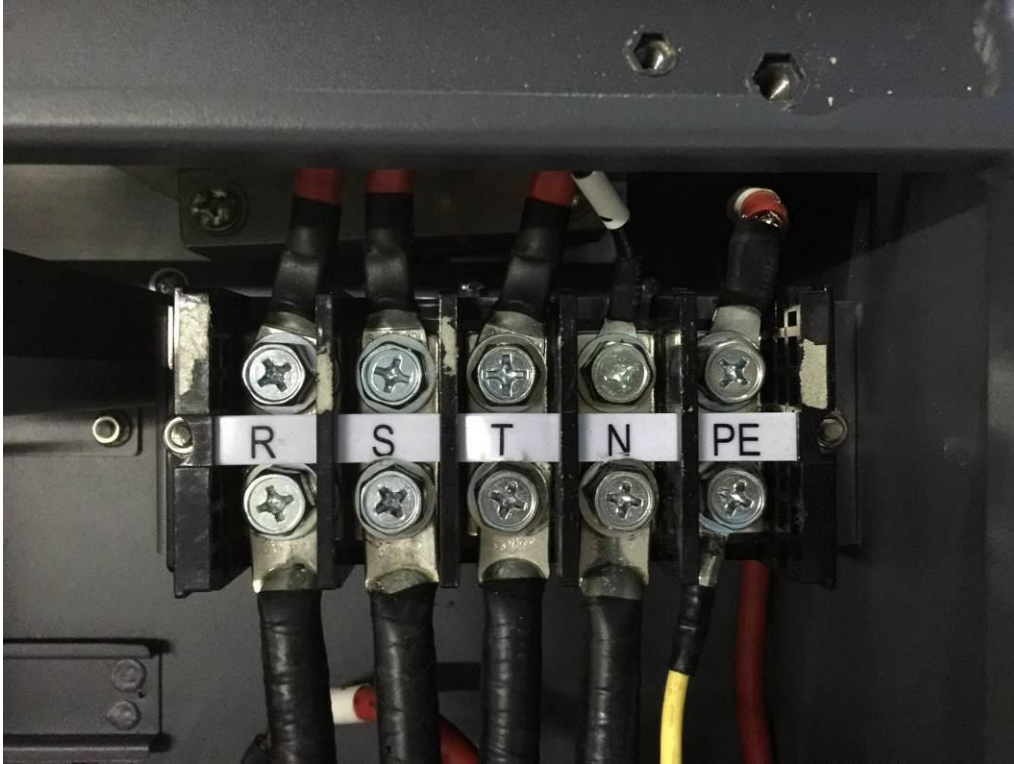

External Eathing connection terminal



Side view

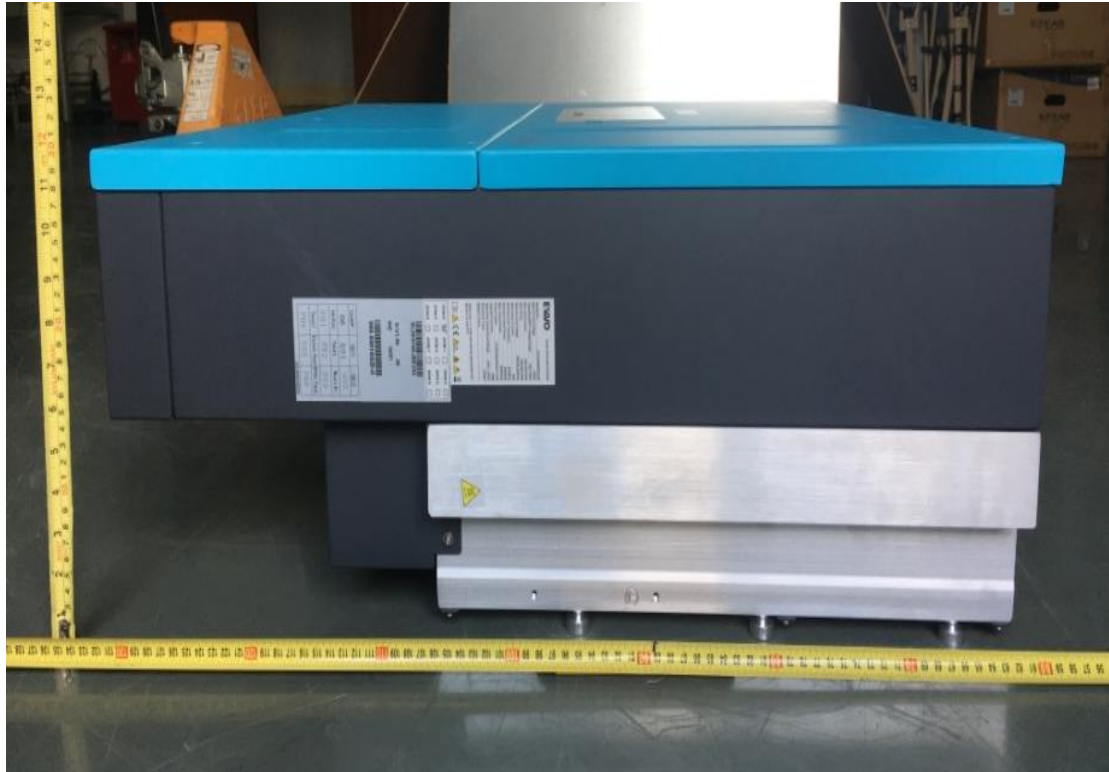

Serial Number: ZJ1ES160HCJ252



Software Version: V2.00



1.2 ELECTRICAL SCHEMES

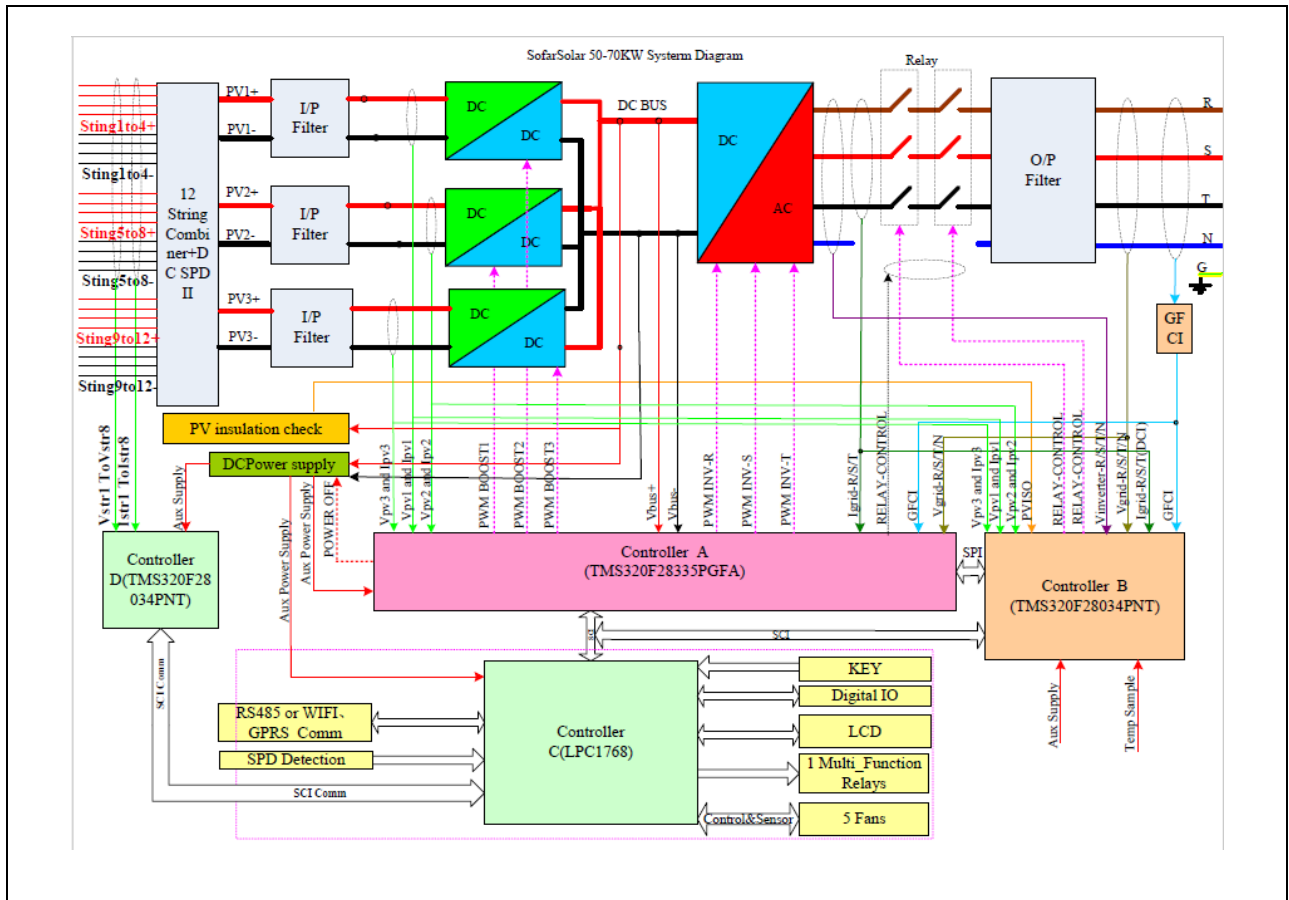

Attachment II

(Testing information)

2.1 TESTING CIRCUIT

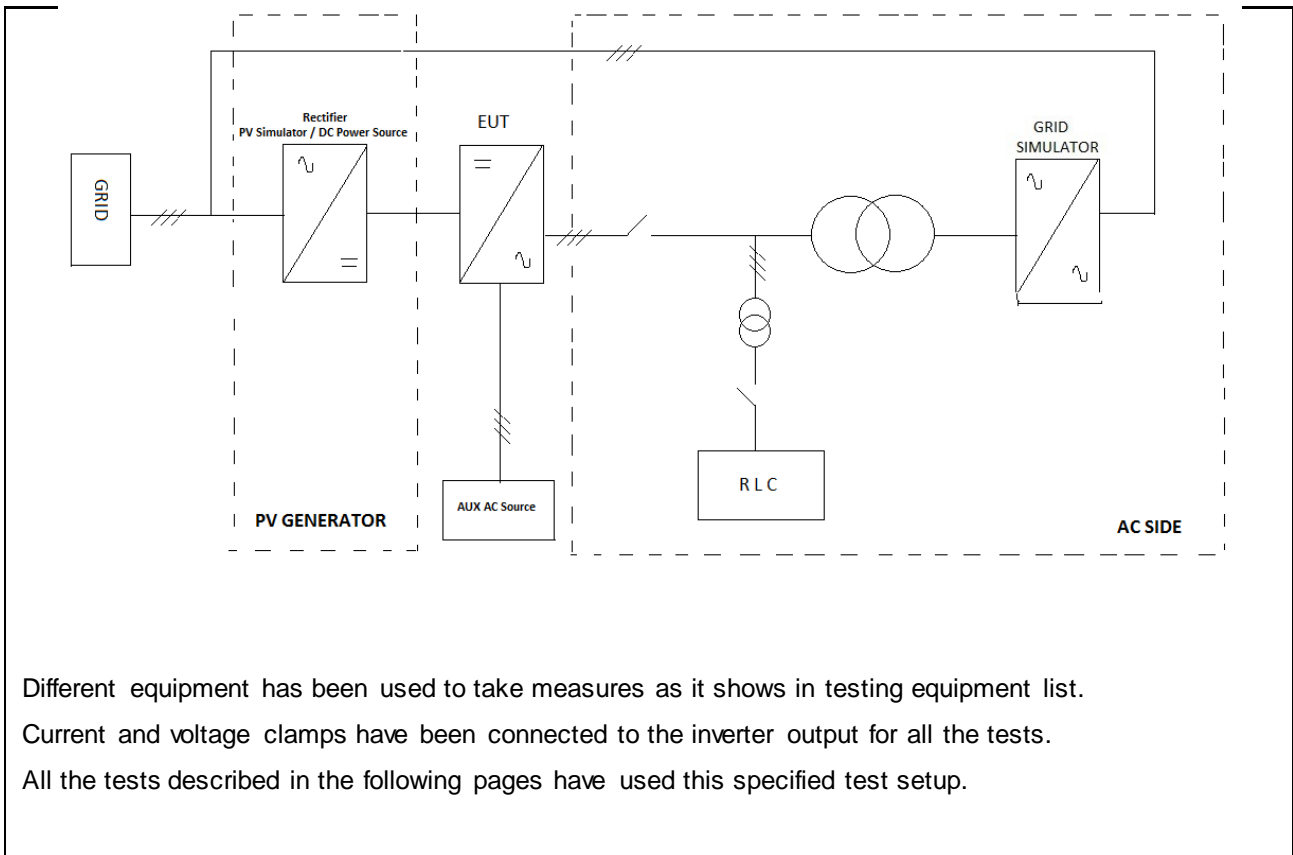

Different equipment has been used to take measures as it shows in testing equipment list.
Current and voltage clamps have been connected to the inverter output for all the tests.
All the tests described in the following pages have used this specified test setup.

2.2 MEASUREMENT UNCERTAINTY

Magnitude	Uncertainty
Voltage measurement uncertainty	±1.5 %
Current measurement uncertainty	±2.0 %
Frequency measurement uncertainty	±0.2 %
Time measurement uncertainty	±0.2 %
Power measurement uncertainty	±2.5 %
Phase Angle	±1°
Temperature	±3° C

Note1: Measurements uncertainties showed in this table are maximum allowable uncertainties. The measurement uncertainties associated with other parameters measured during the tests are in the laboratory at disposal of the solicitant.